

An architectural rendering of a modern building complex, the Creal Centre Project, situated on a rocky, desert-like terrain. The building features a prominent glass-enclosed structure on the left and a long, low-profile main building with a series of rectangular protrusions along its front facade. The background shows a clear sky and several palm trees. The overall aesthetic is clean and futuristic.

REGENRATIVE SHORELINES
ADAPTIVE TECHTONICS

THE CREAL CENTRE PROJECT

DESIGN PRACTICE 2

SARA *MOTWANI*

THE COLOUR SCHEME OF THE PORTFOLIO IS INSPIRED FROM THE SIGNAGE THAT WAS OBSERVED THROUGHOUT THE TOWN



109





UNDERSTANDING DEMOGRAPHICS

POPULATION DISTRIBUTION OF GREAT YARMOUTH BY AGE

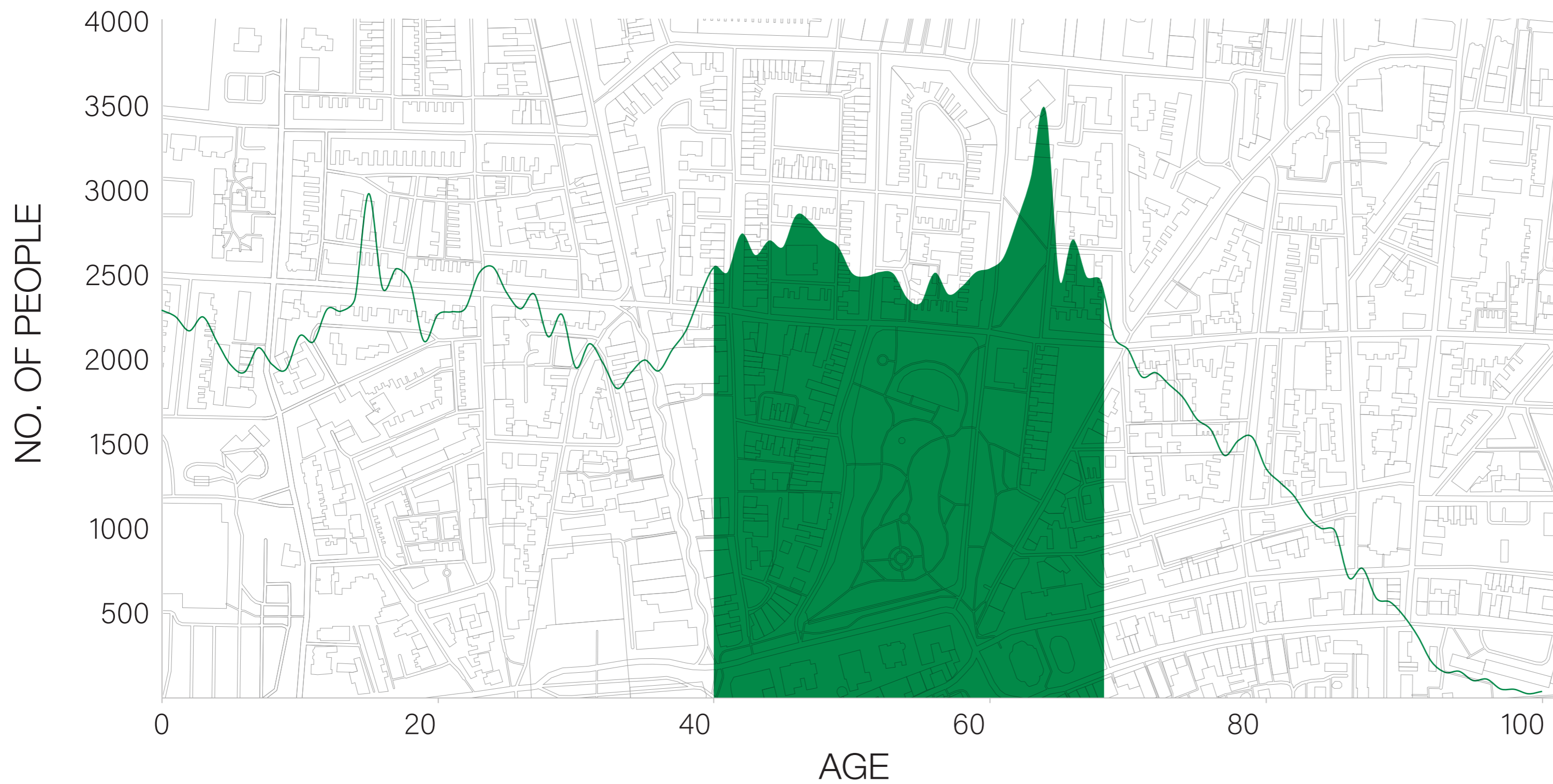

COMPARATIVE LIFE EXPECTANCY



PREVALENT HEALTH CONDITIONS IN GREAT YARMOUTH

WELLNESS TOURISM

IN THE UK 1 IN 5 PEOPLE TAKE ATLEAST 1 WELLNESS BREAK A YEAR

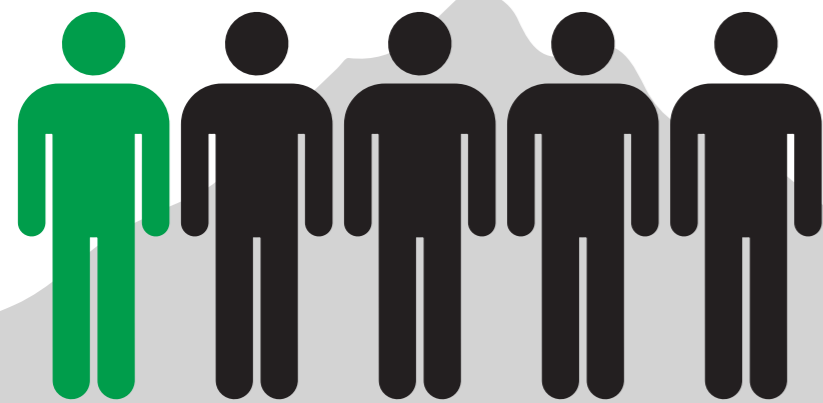

ONLY

8%

ARE IN COASTAL DESTINATIONS

NATURAL SETTING



SPA FACILITIES



ACCOMMODATION



CULTURE



LOCAL EXPERIENCE



HEALTH CLASSES



IMPORTANCE OF DECISION DRIVERS FOR TRIPS

PRE - FAMILY ■
FAMILY ■
EMPTY NESTERS ■



WELLNESS TOURISM IS ONE OF THE FASTEST GROWING MARKET, RISING 12.5% FROM 2012-13, OUTPACING THE PROJECTED 9% AND WORTH AN ESTIMATED £ 314.8 BILLION IN REVENUES.

NET LIKELIHOOD TO TAKE A WELLNESS BREAK BY MONTH



STANDARD

WELLNESS

HEDONISTIC

MAIN PURPOSE OF OVERNIGHT LEISURE TRIPS

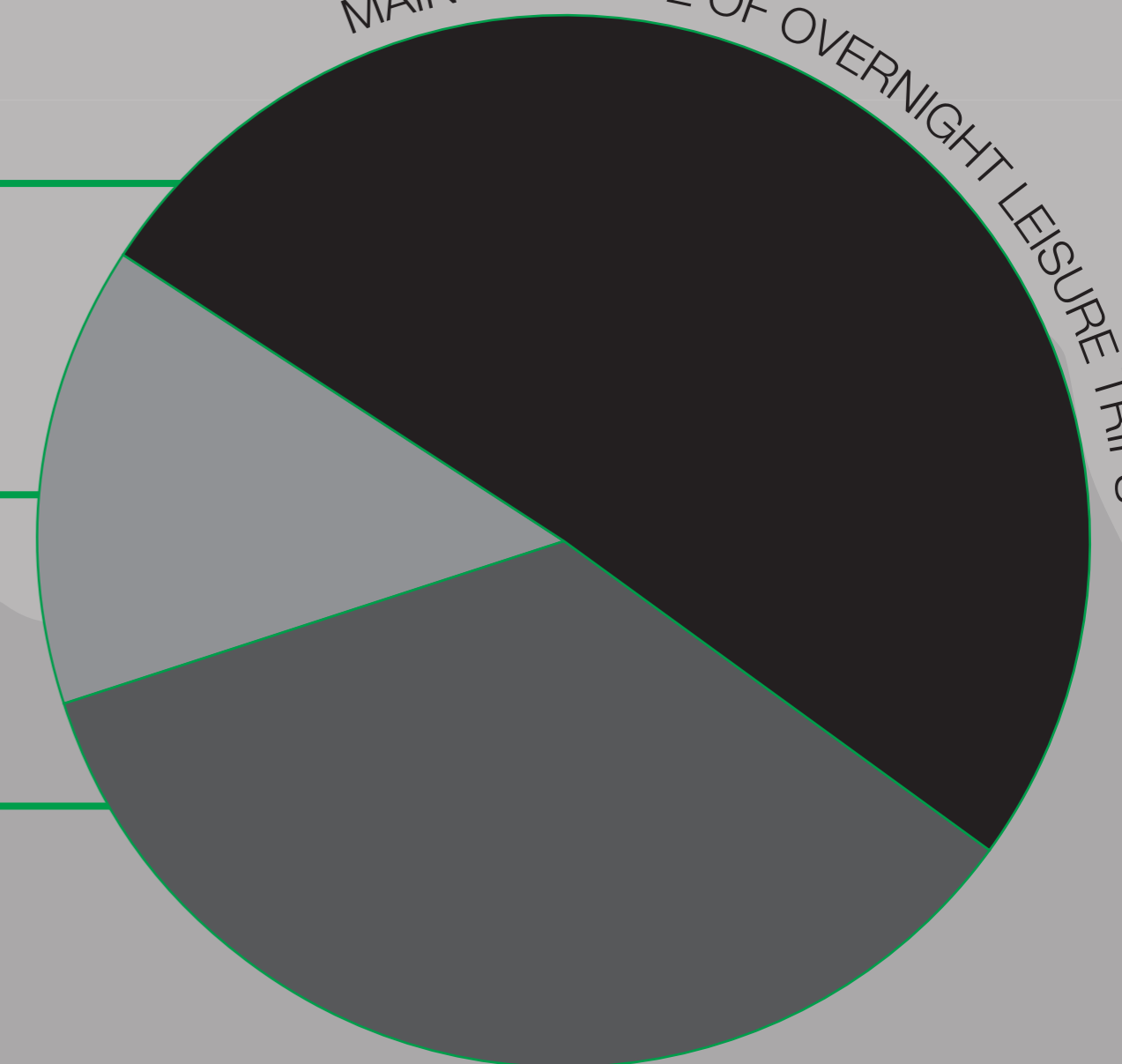

ART TOURISM

OUT THERE

INTERNATIONAL FESTIVAL OF CIRCUS & STREET ARTS

£ 3,100,000

ECONOMIC IMPACT
IN GREAT YARMOUTH

40+

COMPANIES
WORKED WITH

60,000+

IN
ATTENDANCE

OUT THERE ARTS IS AN INDEPENDENT ARTS DEVELOPMENT CHARITY IN GREAT YARMOUTH THAT COLLABORATES WITH ARTISTS WORLDWIDE. THEY DELIVER OUTSTANDING OPPURTUNITIES FOR ARTISTS AND COMMUNITIES THROUGH SUPPORTING, HOSTING, AND DELIVERING CIRCUS AND STREET ARTS PROJECTS AND EVENTS.

GREAT YARMOUTH HAS RICH CULTURE AND HERITAGE AS IS EVIDENT FROM THE DIVERSE BUILDINGS OF HISTORIC AND CULTURAL SIGNIFICANCE PRESENT.



BILBAO EFFECT



1 MILLION
VISITORS A YEAR

88%



TOURISTS

SINCE THE EARLY 2000s THE 'BILBAO EFFECT' BECAME A RECOGNISED FORM OF REGENARATION WHERE THE ATTRACTION OF NEW INVESTMENT COULD BE CATALYSED FROM THE FLOWS OF ART TOURISTS TO A FLAGSHIP ART GALLERY



UNWTO

UNITED NATIONS WORLD
TOURISM ORGANISATION

THE UNWTO IS MAKING SINCERE EFFORTS TO FORTIFY THE ART TOURISM SECTOR BY BRINGING NEW INITIATIVES THAT PROFIT UNDERVALUED ARTISTS

COST OF LIVING
 RENT
 GROCERIES
 RESTAURANTS

THESE INDEX FIGURES ARE BASED ON COST OF LIVING CRITERIA WHICH CREATE A DATA POINT FROM 0-100 IN A RISING EXPENSE SCALE.

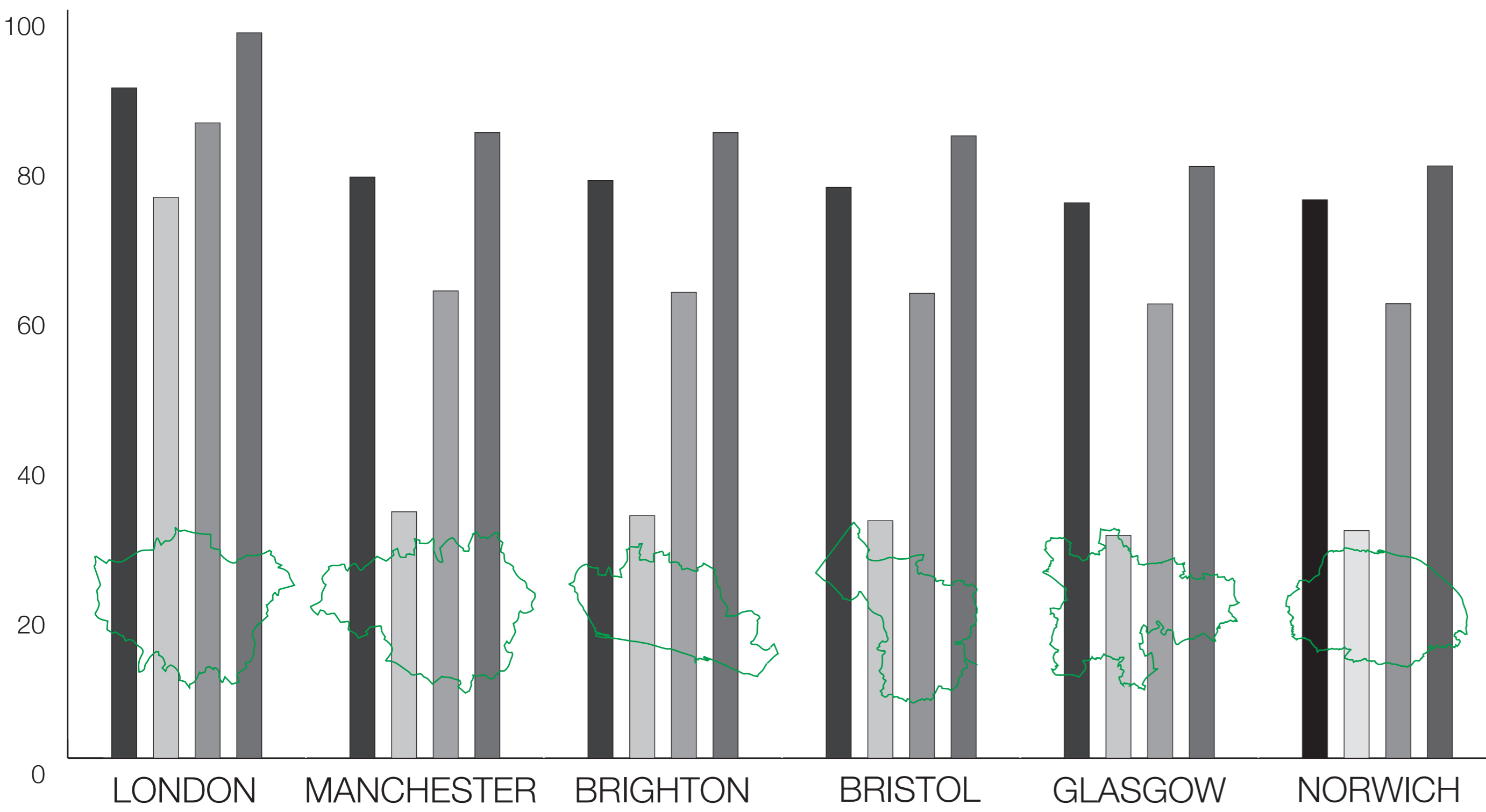

CITIES THAT ARE CONSIDERED OF ART HUBS IN THE UK

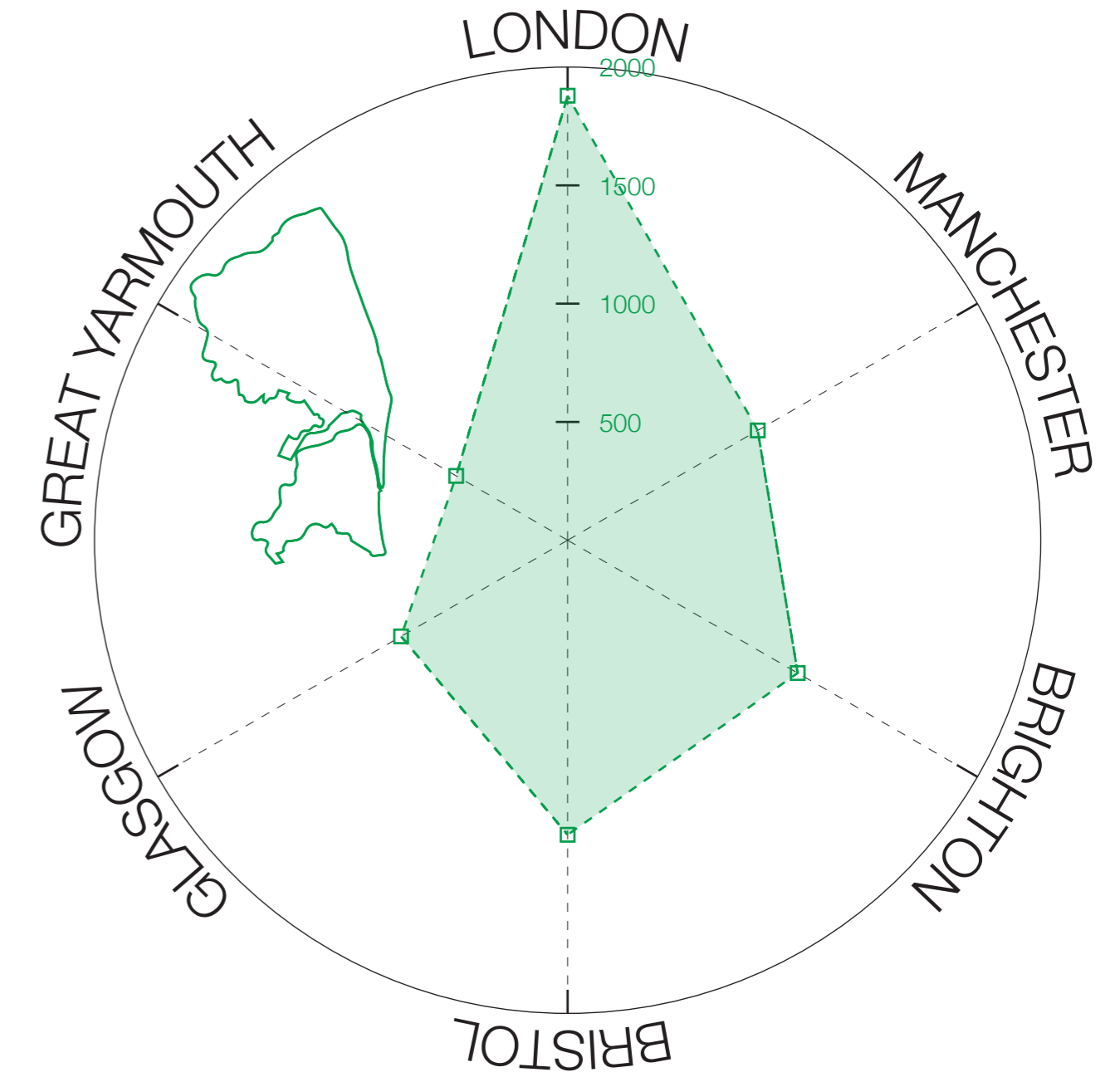

AVERAGE RENT (PCM) COMPARISON

FACTORS RESULTING IN FLOURISHING ART CULTURE IN THESE CITIES

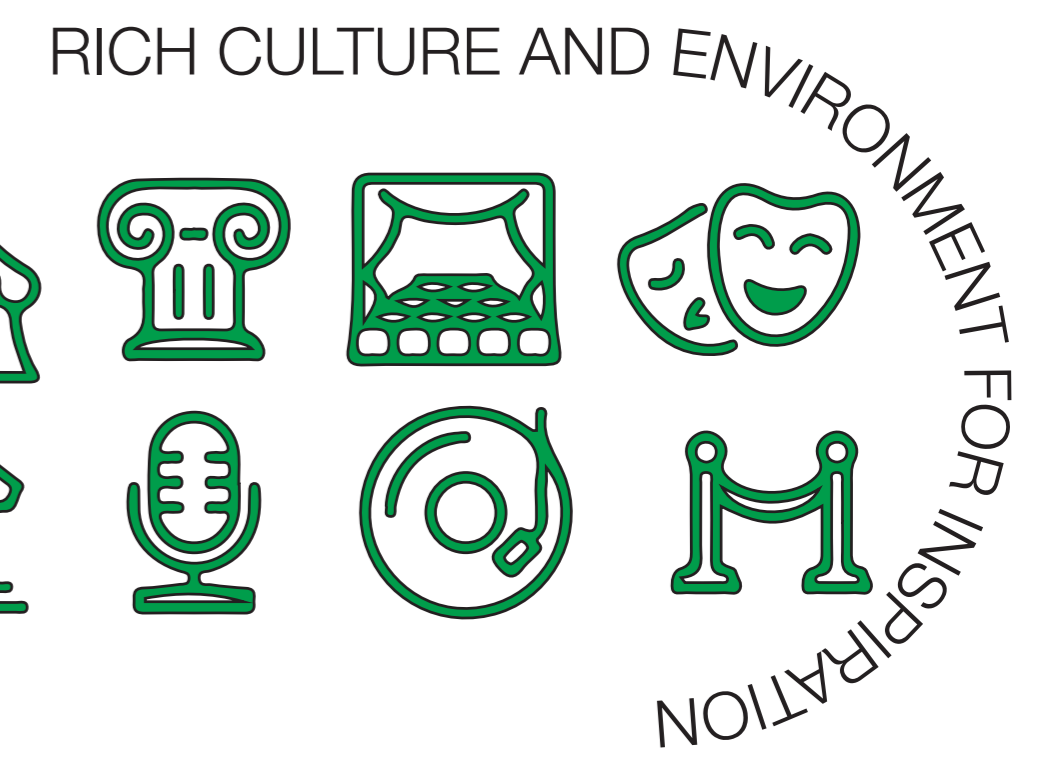
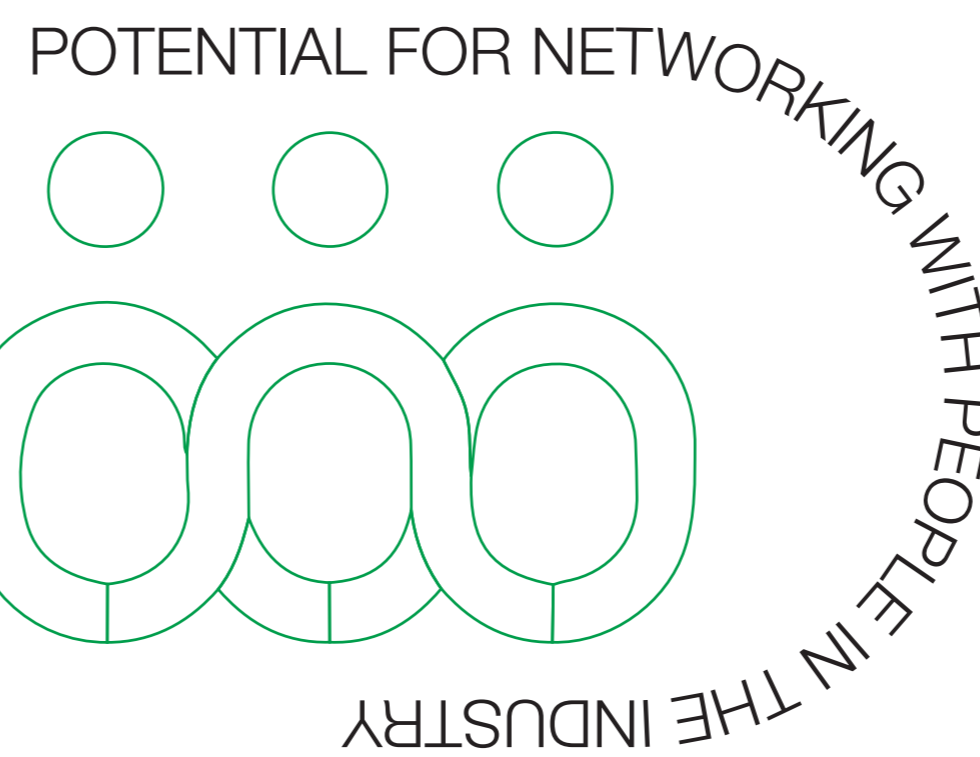
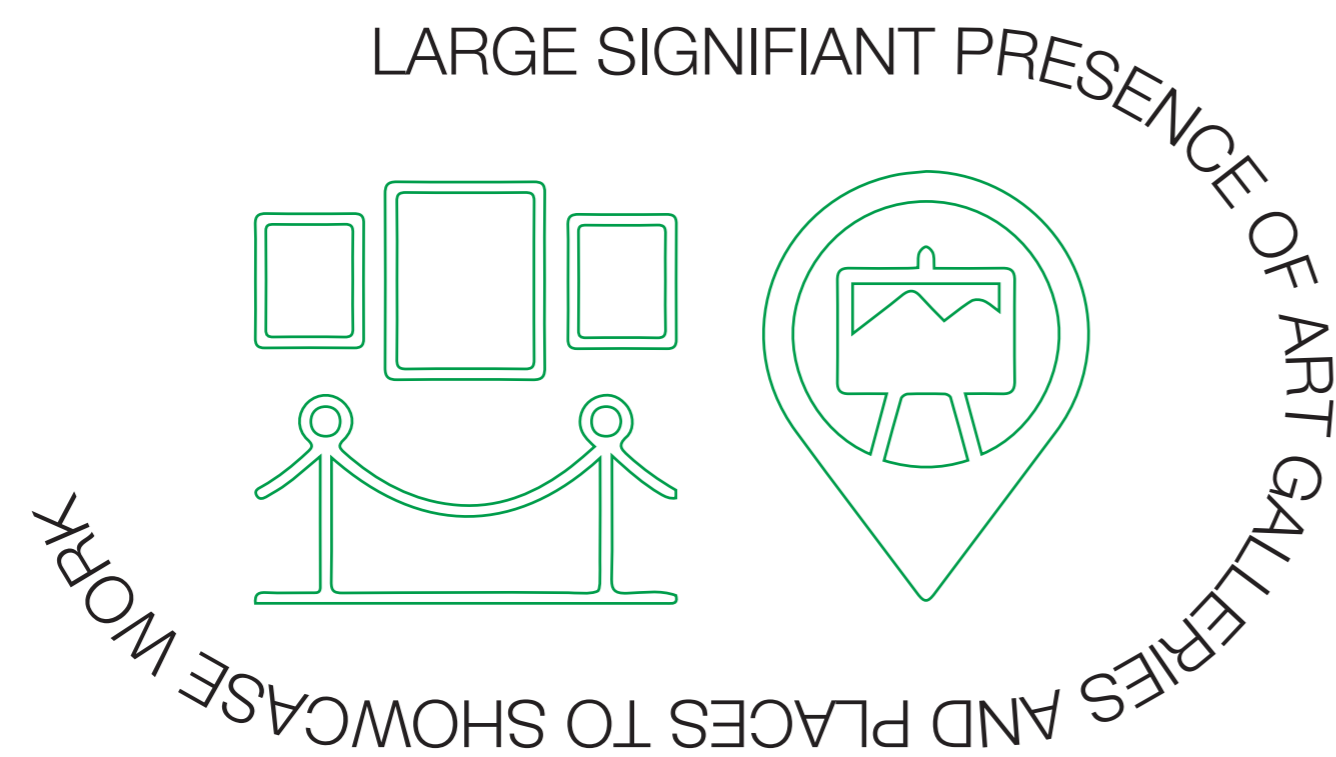

THE POINTS OF INTEREST FOR THE PROJECT MUST FOCUS ON 'CREATING' AND 'HEALING'

CREATE + HEAL

'THE CREAL CENTRE PROJECT'

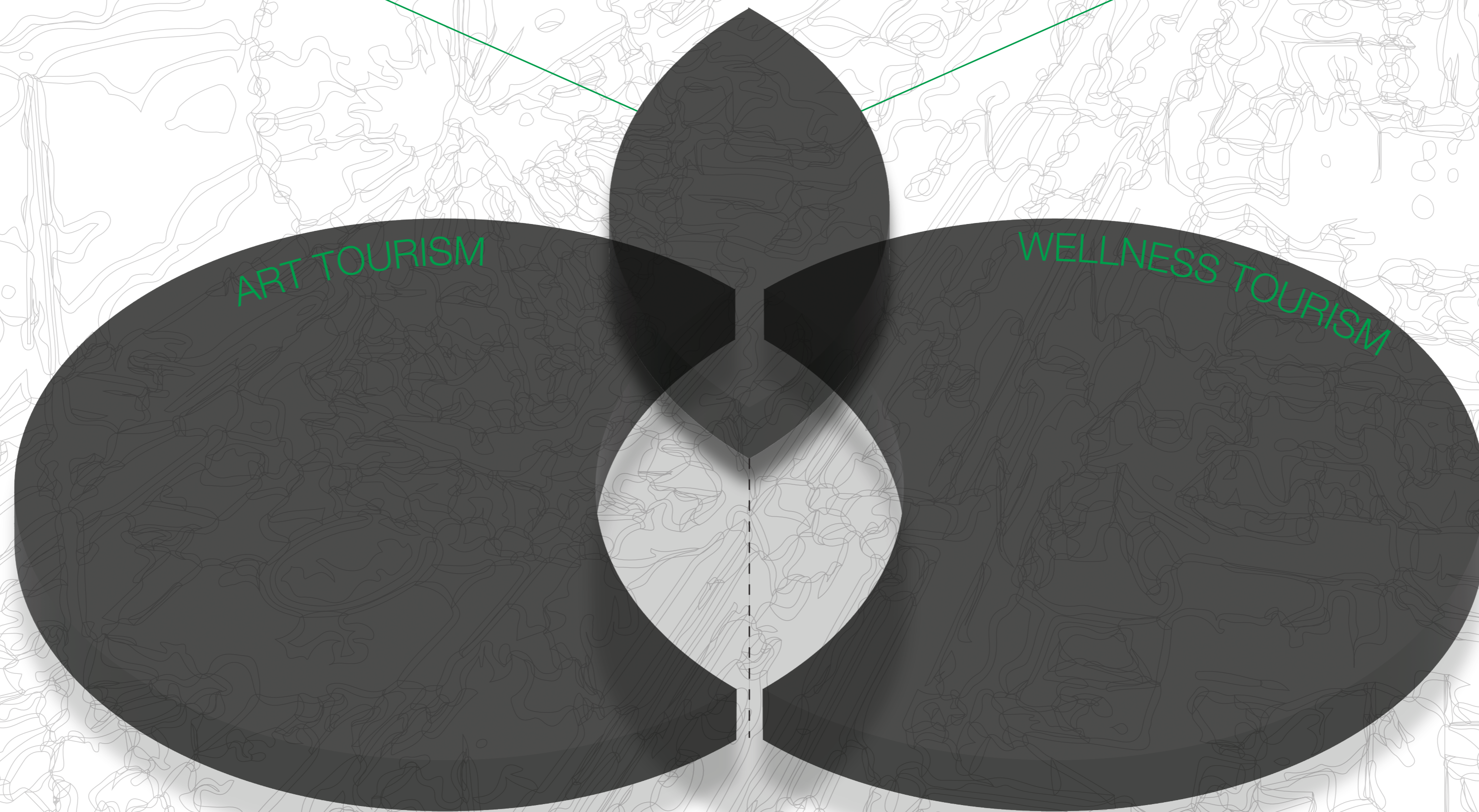

An architectural rendering of a modern building complex. The main building is a long, low-profile structure with a curved facade and a series of windows. In front of it are several smaller, rectangular structures with large windows. The scene is set in a desert landscape with palm trees and a clear sky. The text "THE ACTIVITY & ITS REQUIREMENTS" is overlaid in the center, with "REQUIREMENTS" in green.

THE ACTIVITY & ITS REQUIREMENTS

ART THERAPY :

ARTS AND CREATIVE THERAPIES ARE TREATMENTS WHICH INVOLVE ART ACTIVITIES WITHIN THERAPY SESSIONS. THESE SESSIONS ARE SUPPORTED BY A TRAINED PROFESSIONAL. YOU DON'T NEED TO HAVE ANY SKILLS OR EXPERIENCE IN ART AND PEOPLE OF ANY AGE CAN BENEFIT FROM THEM.



PERFORMANCE ARTS

VISUAL ART

FORMS OF VISUAL ART THERAPY

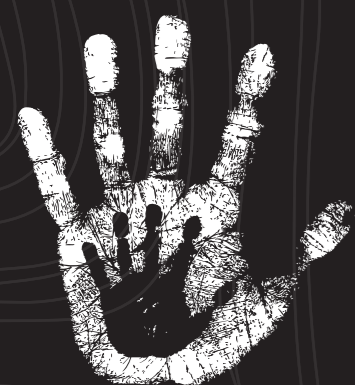

FINGER PAINTING



CLAY POTTERY



SCRIBBLING

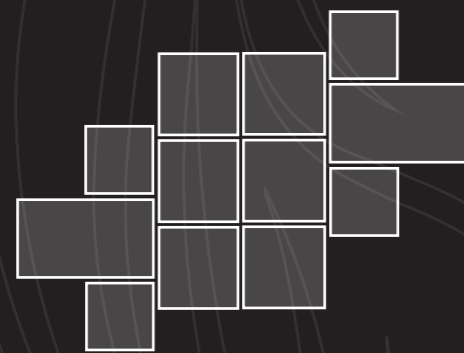

COLLAGING



ZENTANGLING



SKETCHING PAINTING

UNDERSTANDING ART THERAPY

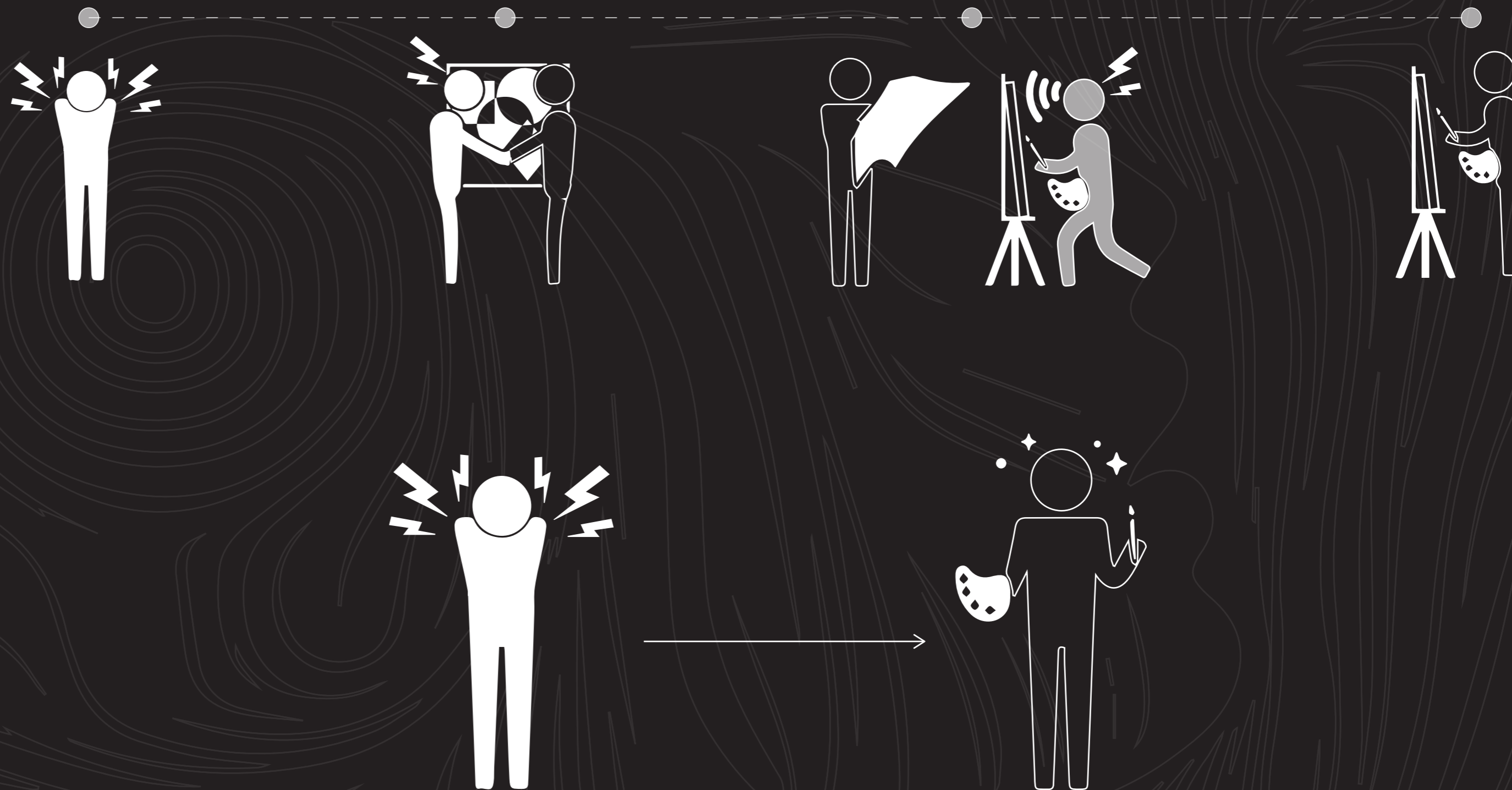

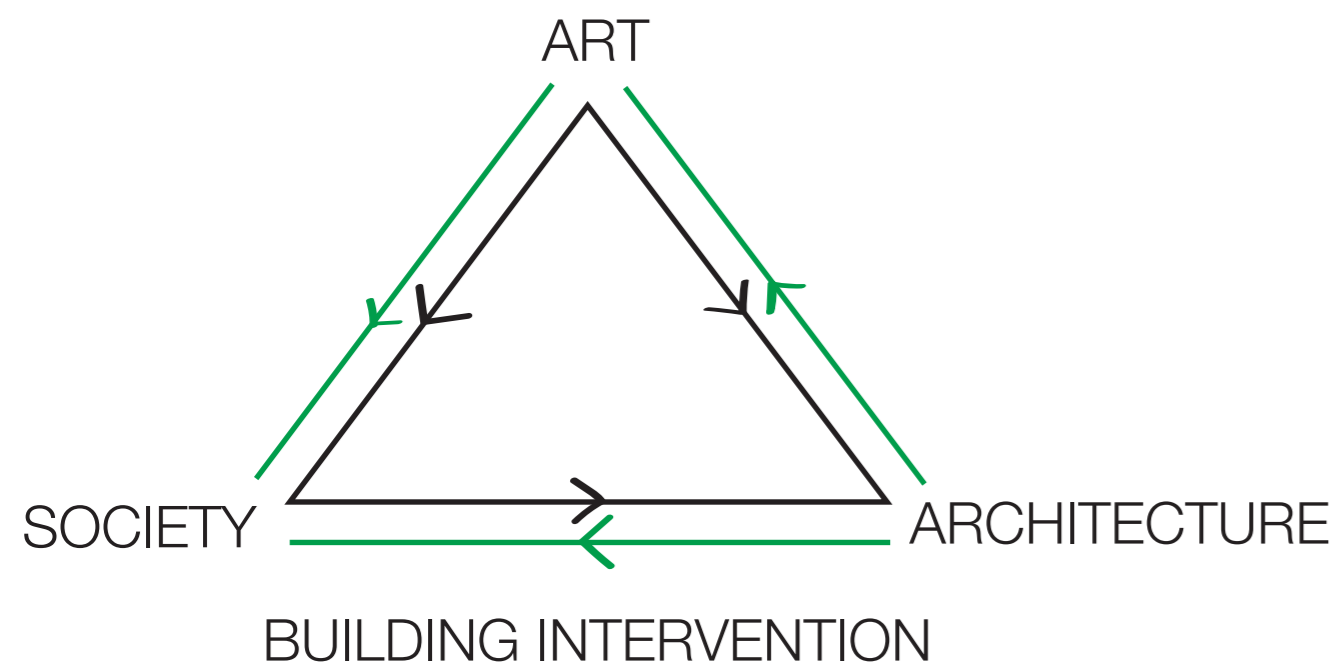
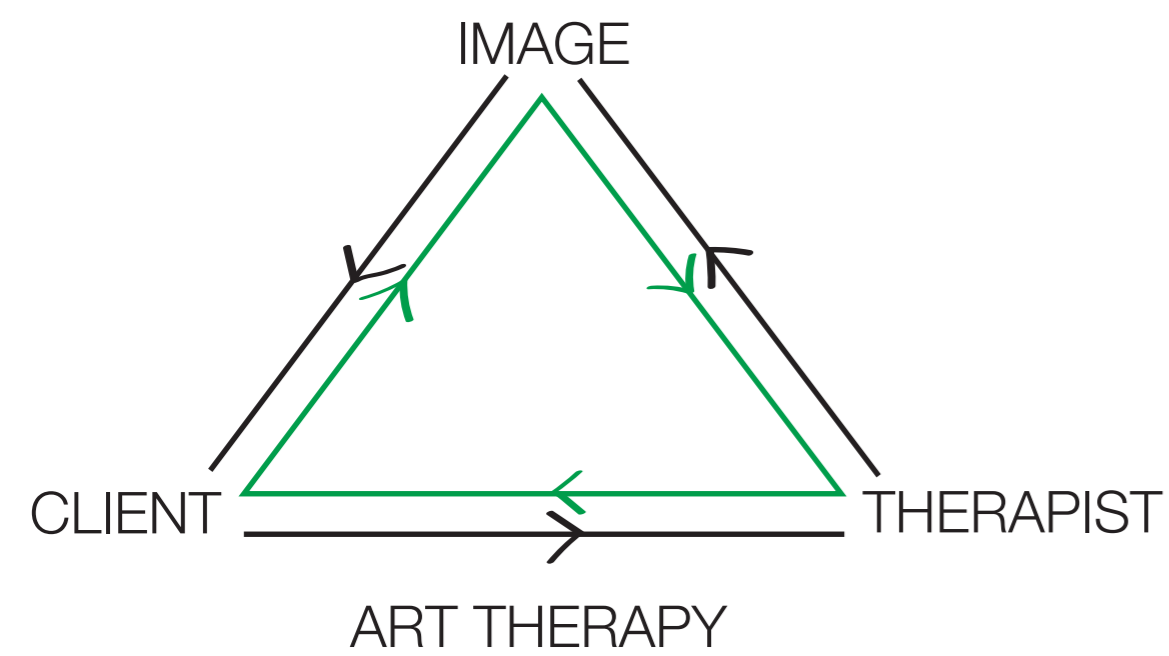

THE FLOW OF ART THERAPY DURING A THERAPY SESSION CAN BE COMPARED TO AN ARCHITECT DESIGNING BUILDING

SPACE DESIGN REQUIREMENTS

“ HEALING + RECOVERY + CREATIVITY ARE BROUGHT ABOUT BY HOW WE FEEL IN A SPACE ”



INTEGRATING BUILDING WITH NATURE - CREATING SPACES WITH AN INDOOR-OUTDOOR RELATIONSHIP

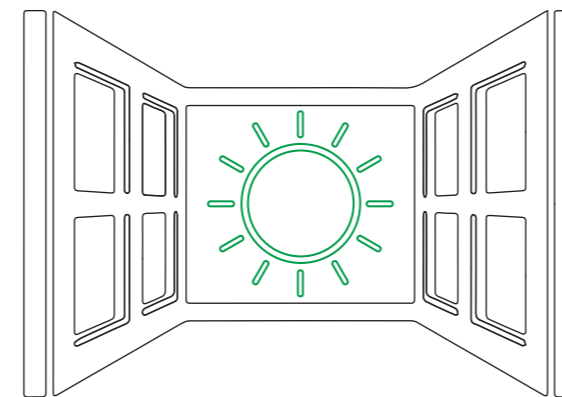

WINDOWS ARE A 'PORTAL' INTO HEALTH

LARGE WINDOWS AND SKYLIGHTS FOR MORE NATURAL LIGHT

RESEARCH SHOWS PATIENTS NEAR WINDOWS HEAL FASTER

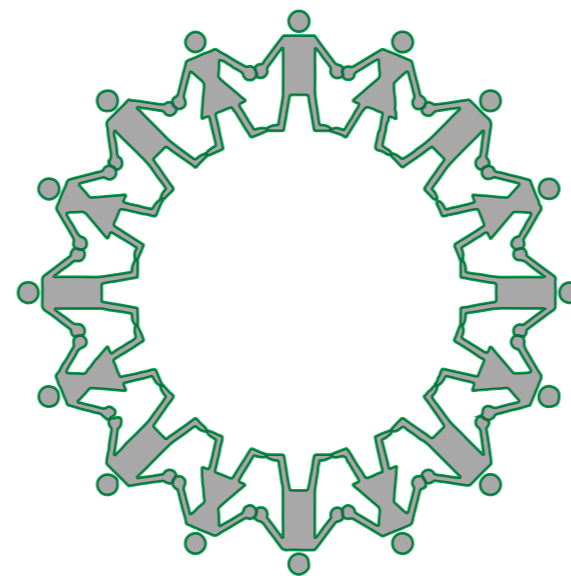

CREATING SPACES THAT INCREASES HUMAN INTERACTION INSTEAD OF CREATING AN ISOLATED EXPERIENCE FOR THE USE OF THE BUILDING

LOCATION BY THE COAST

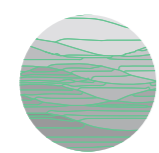

THE COLOUR BLUE BRINGS CALM AND SPARKS CREATIVITY WHICH IS IDEAL FOR ART THERAPY AND ARTIST STUDIO SPACES

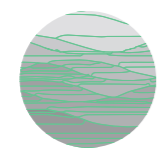

WAVE-WATCHING CAN REDUCE STRESS LEVELS

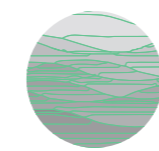

LISTENING TO THE SOUNDS OF THE SEA RELAXES THE BRAIN

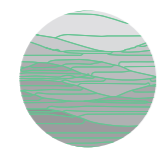

BREATHING SEA AIR HELPS YOU SLEEP

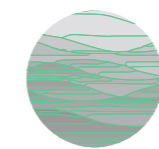

COASTAL SETTINGS CAN REDUCE THE NEED FOR ANTIDEPRESSANTS

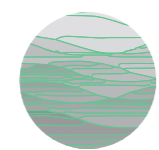

THE BEACH ENCOURAGES SOCIAL BONDS

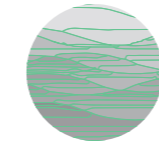

BEING BY (AND IN) THE OCEAN INCREASES YOUR HAPPY HORMONES

An architectural rendering of a modern building complex. The main building is a long, low-profile structure with a curved glass entrance on the left. In front of it are several smaller, rectangular units with windows. The scene is set in a desert-like environment with palm trees and a clear sky. The text 'MAPPING COMMODITIES' is overlaid in the center.

MAPPING COMMODITIES



+ ART EDUCATION

* ART GALLERIES

⌘ ARTS AND CULTURE VENUES



✚ MENTAL HEALTH TREATMENT

✱ PHYSICAL THERAPY

⌘ WELLBEING CENTRE



 PLACES OF BEACH/SEA-SIDE AMUSEMENT

An architectural rendering of a modern building complex. The main building is a long, curved structure with a flat roof and a series of windows. In the foreground, there are several smaller, rectangular structures with large windows. The background features palm trees and a clear sky. The overall scene is presented in a light, semi-transparent style.

PROGRAMME AND ADJACENCIES

ARTIST IN RESIDENCE PROGRAM

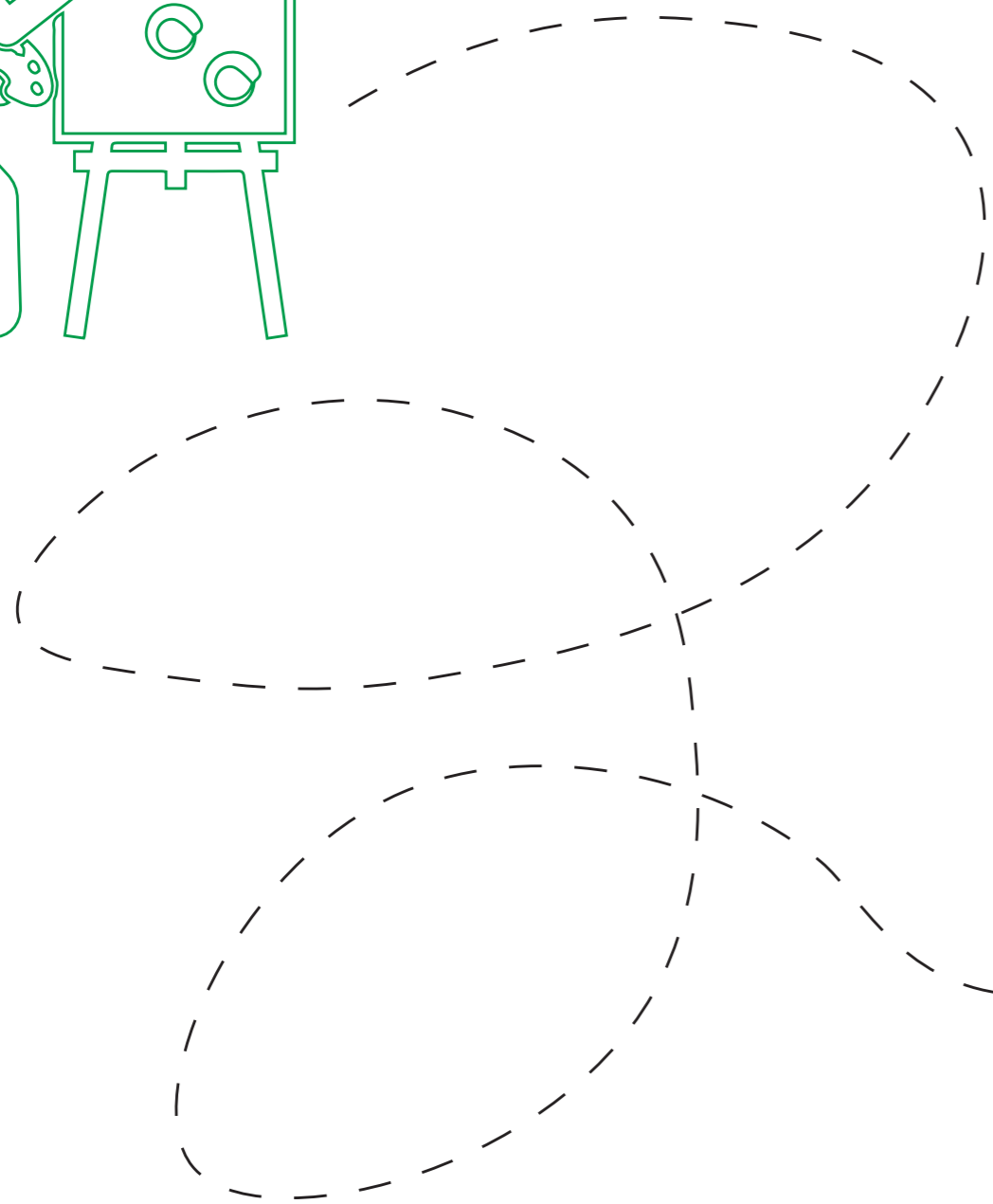
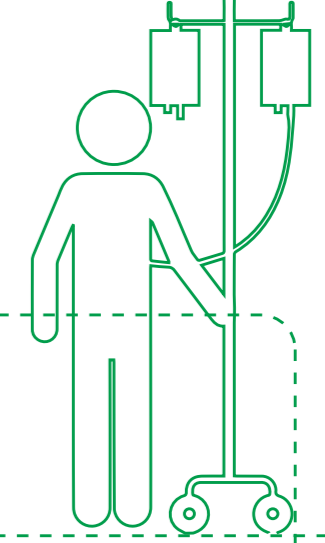
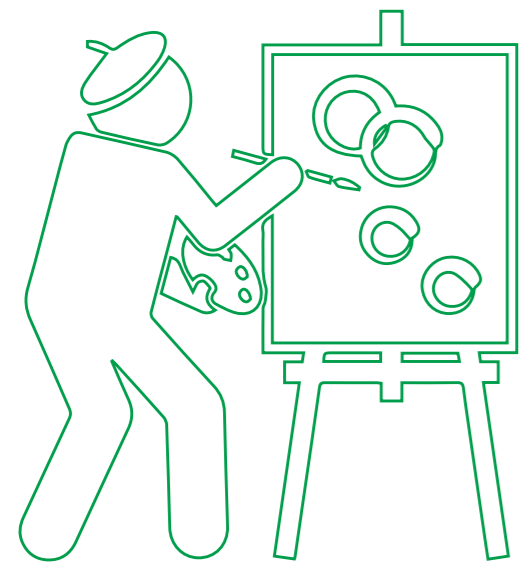

UNDERGO ART THERAPY TRAINING

ARTIST STUDIO SPACES AVAILABLE

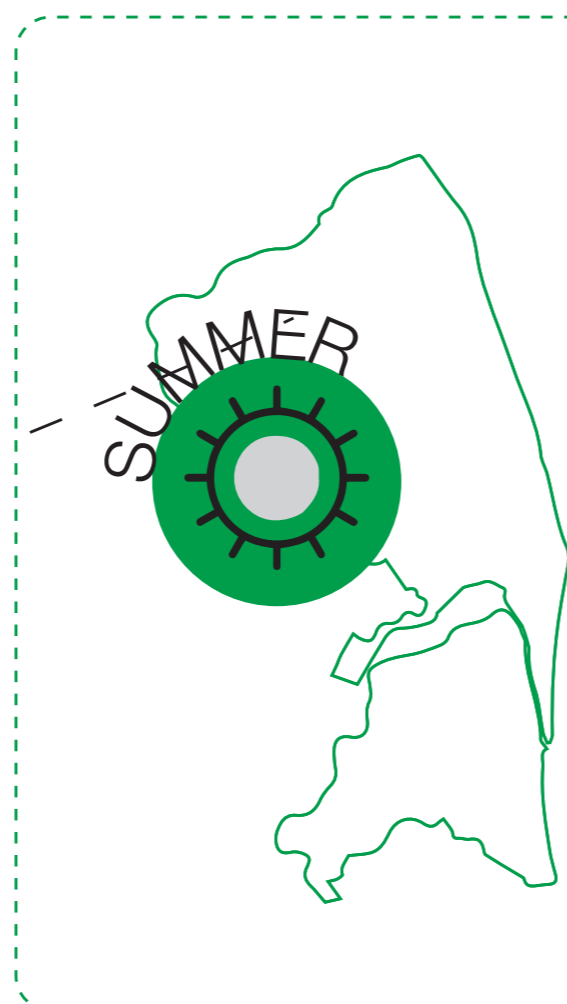
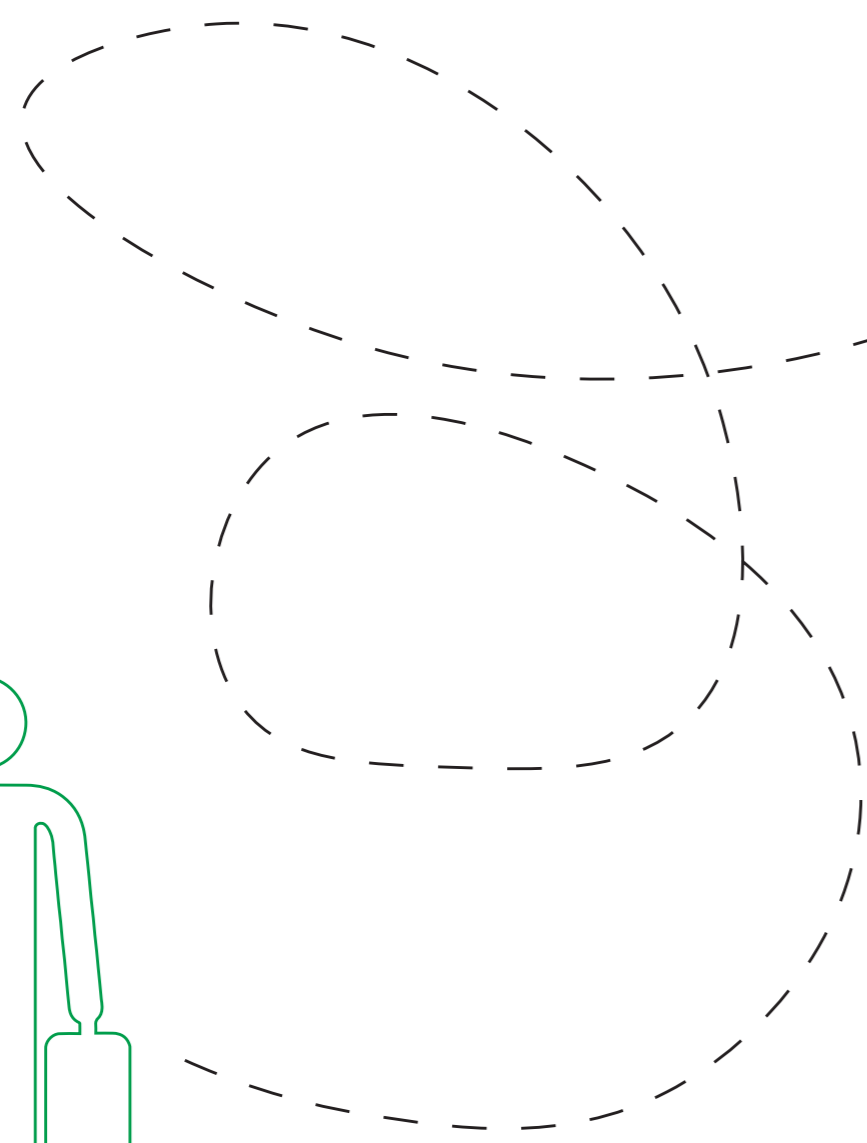

ART THERAPY RETREAT

ART EXHIBITIONS

ART THERAPY FOR LOCALS

ART THERAPY RETREAT



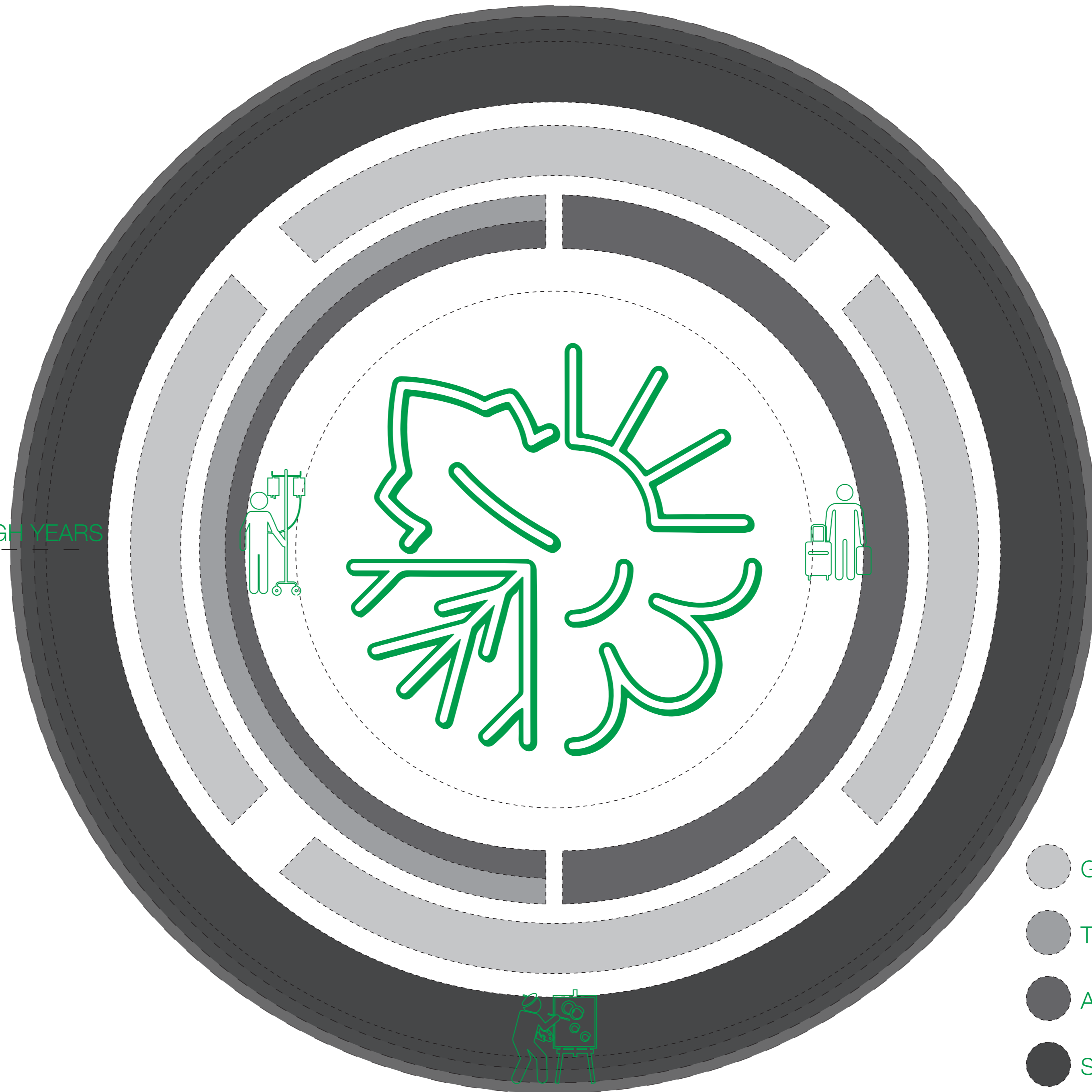

INCREASING THROUGH YEARS



- GALLERY SPACE
- THERAPY TRAINING
- ART THERAPY
- STUDIO SPACES



-  SINGLE USE PERMANENT SPACE
-  MULTI USE ADAPTIVE SPACE
-  EXPANSIVE SPACE

WINTER (OFF-PEAK) SEASON ADJACENCY

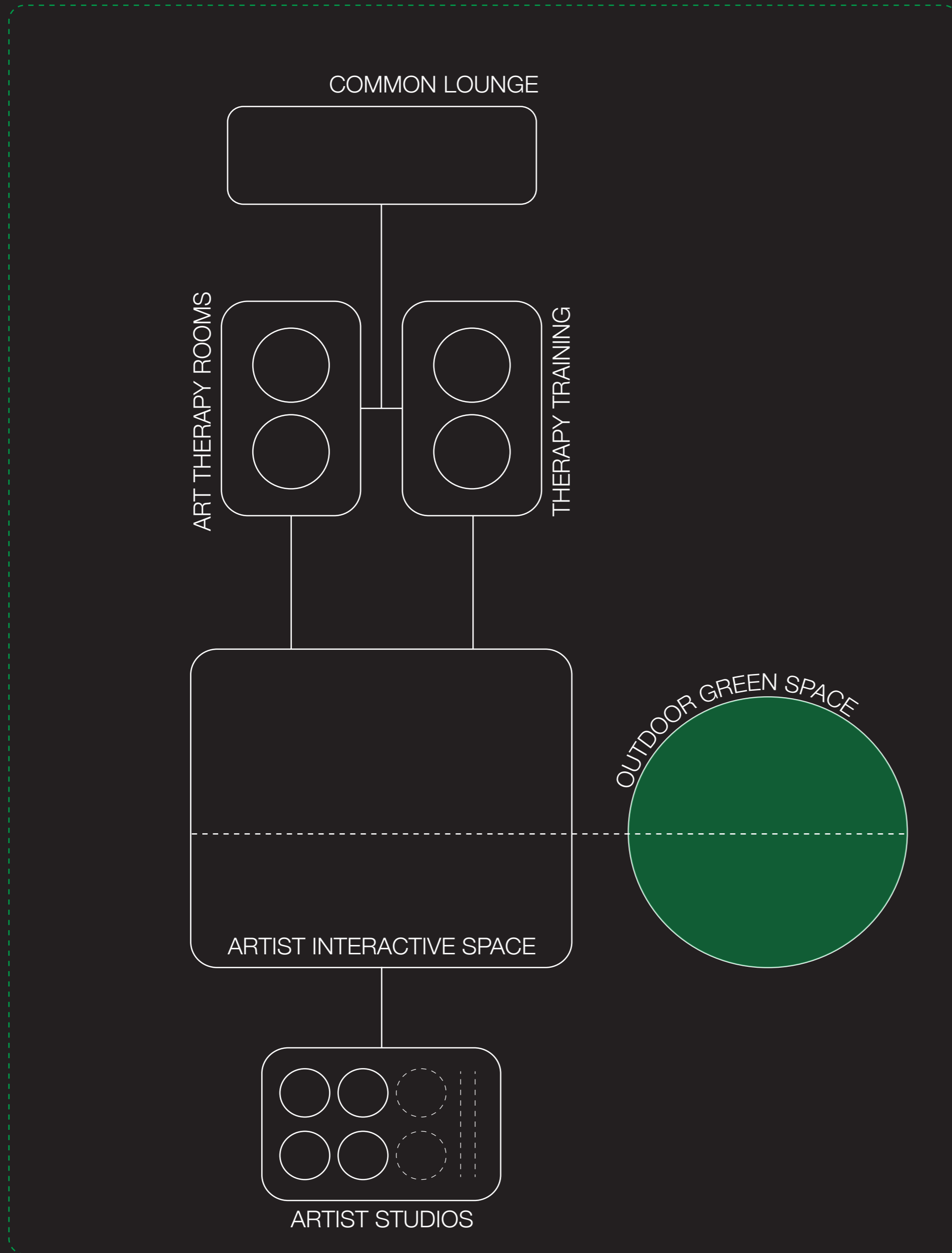

SUMMER (PEAK) SEASON ADJACENCY

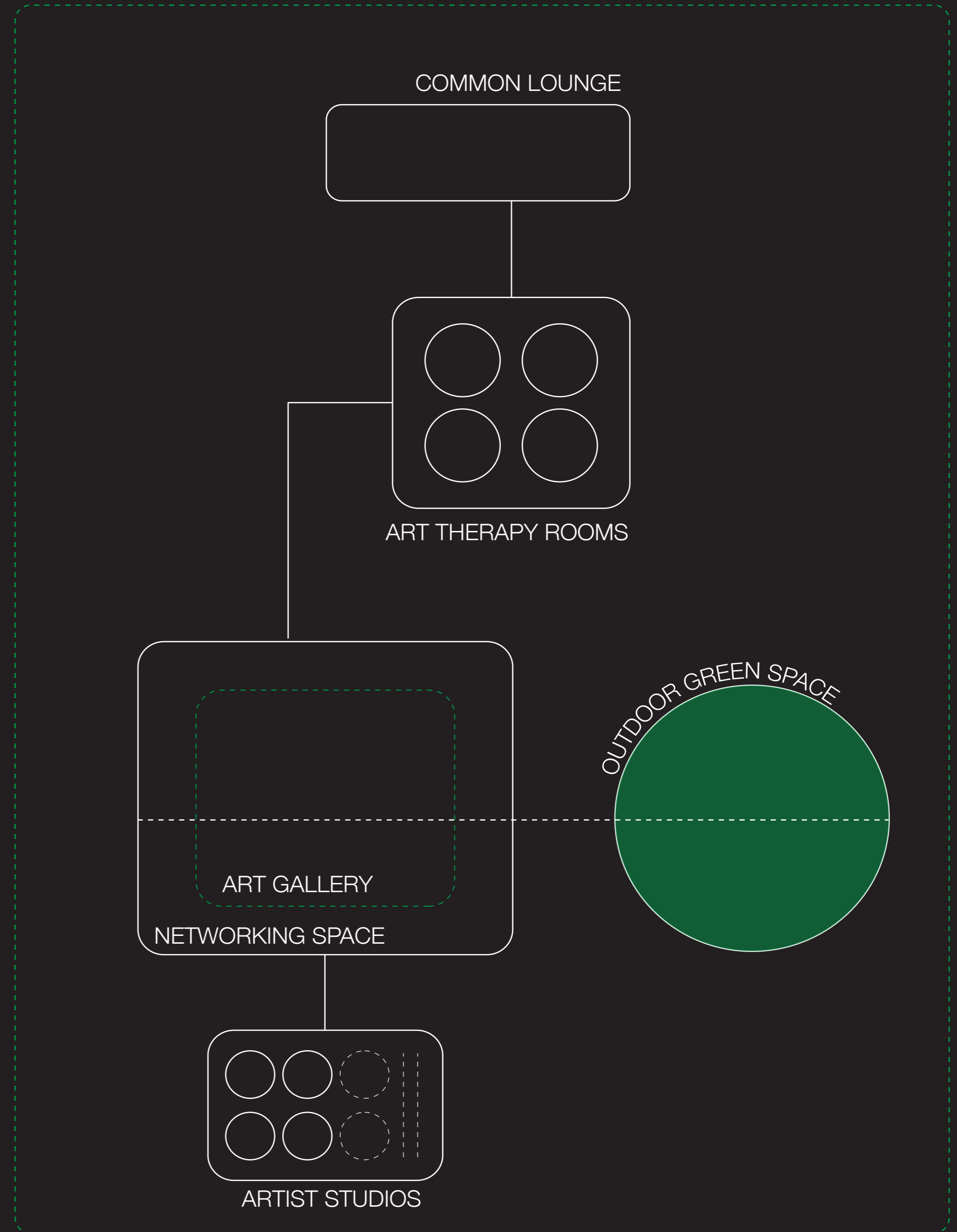

JAN

FEB

MAR

APR

MAY

JUN

JUL

AUG

SEP

OCT

NOV

DEC

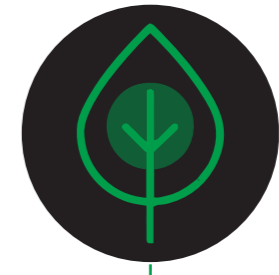
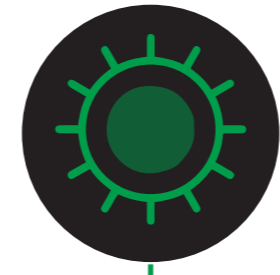
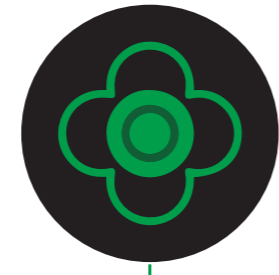
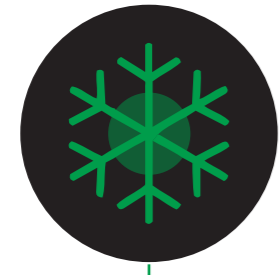

ARTISTS

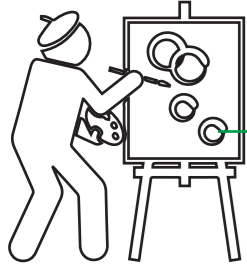

ARTIST INFLUX IS SUPPOSED TO BE ALL YEAR ROUND AND IS EXPECTED TO INCREASE THROUGH TIME AS THE NETWORK AND POPULARITY GROWS

THERAPY SEEKERS

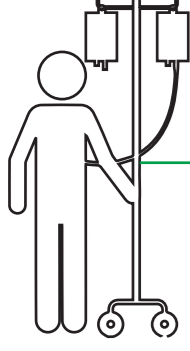

REQUIREMENT FOR THERAPY IS EXPECTED TO BE HIGHER IN WINTERS IN GENERAL, HOWEVER OUT-STATION THERAPY SEEKERS ARE MORE LIKELY TO JOIN IN THE SPRING/SUMMER PERIOD

TOURISTS

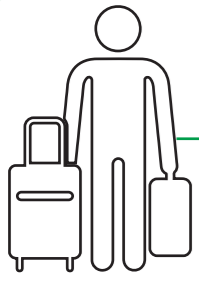

TOURIST ARE MAINLY EXPECTED DURING THE SPRING/SUMMER SEASONS BUT THE OPPORTUNITIES AND ACTIVITY OF THE SPACE MIGHT ATTRACT PEOPLE EVEN IN OFF-PEAK SEASON

LOCALS

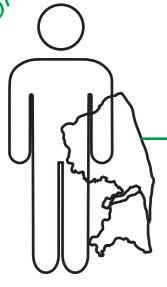

GREAT YARMOUTH LOCALS ARE EXPECTED TO HAVE A STEADY INFLUX THROUGH THE SPACE BUT A SLIGHT DECREASE IS EXPECTED DURING THE WINTERS



SITE+PLANNING INSPIRATIONS

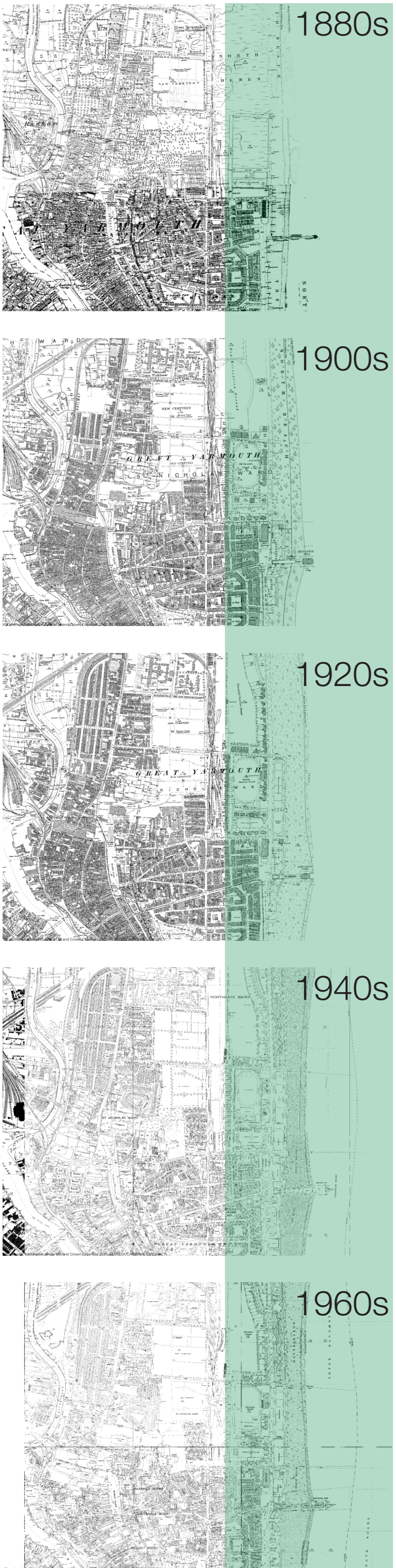

EVOLUTION OF THE SHORELINE OF GREAT YARMOUTH

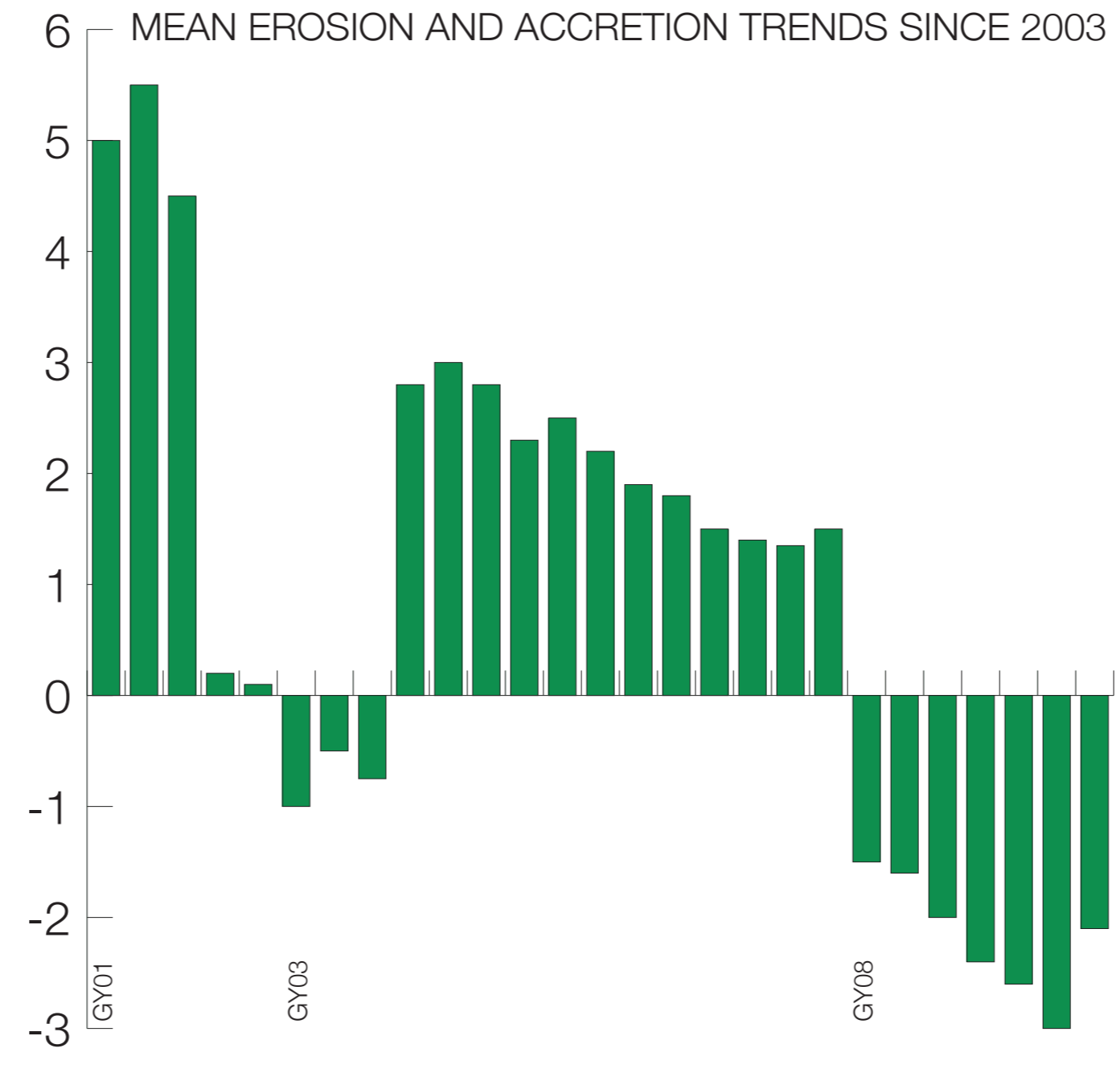

HERRING FISHING IS THE PRIMARY REASON FOR THE GROWTH OF THE GREAT YARMOUTH SHORELINE

THEIR SOUTHWARD MOVE IN AUTUMN ATTRACTED FISHERMAN & MERCHANTS FROM AROUND THE CONTINENT

BY 1330 GREAT YARMOUTH BECAME THE FIFTH WEALTHIEST TOWN DUE TO THE HERRING TRADE

WORKERS, FISHERMEN, COOPERS, AND CURERS, SWELLED THE POPULATION BY 10,000 EACH AUTUMN

GREAT YARMOUTH WAS BUILT ON THE HERRING FISHING AND THE SUBSEQUENT GROWTH OF HERRING TRADE

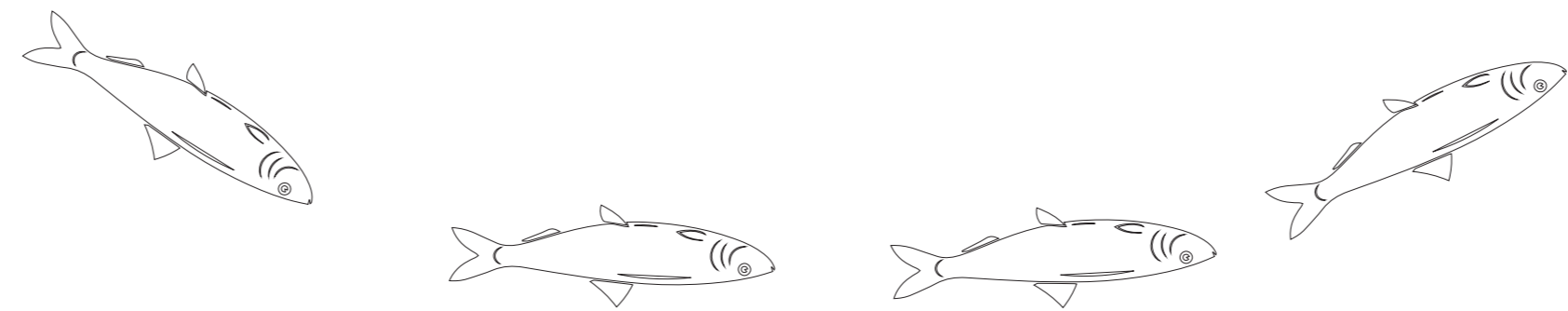

ADVANCING SHORELINE

RETREATING SHORELINE

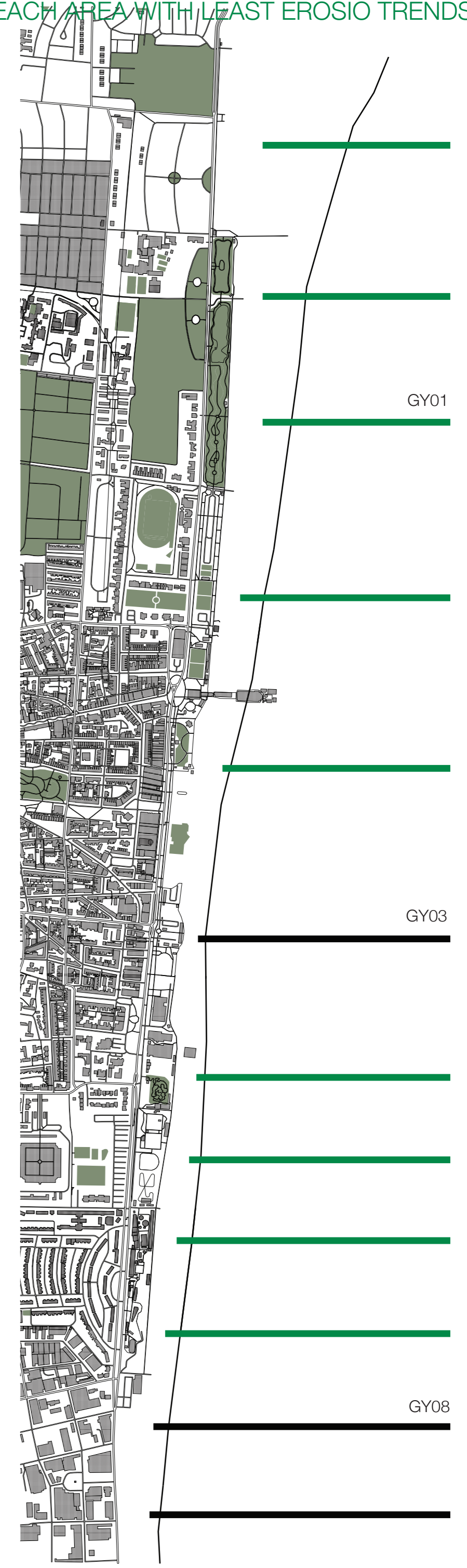

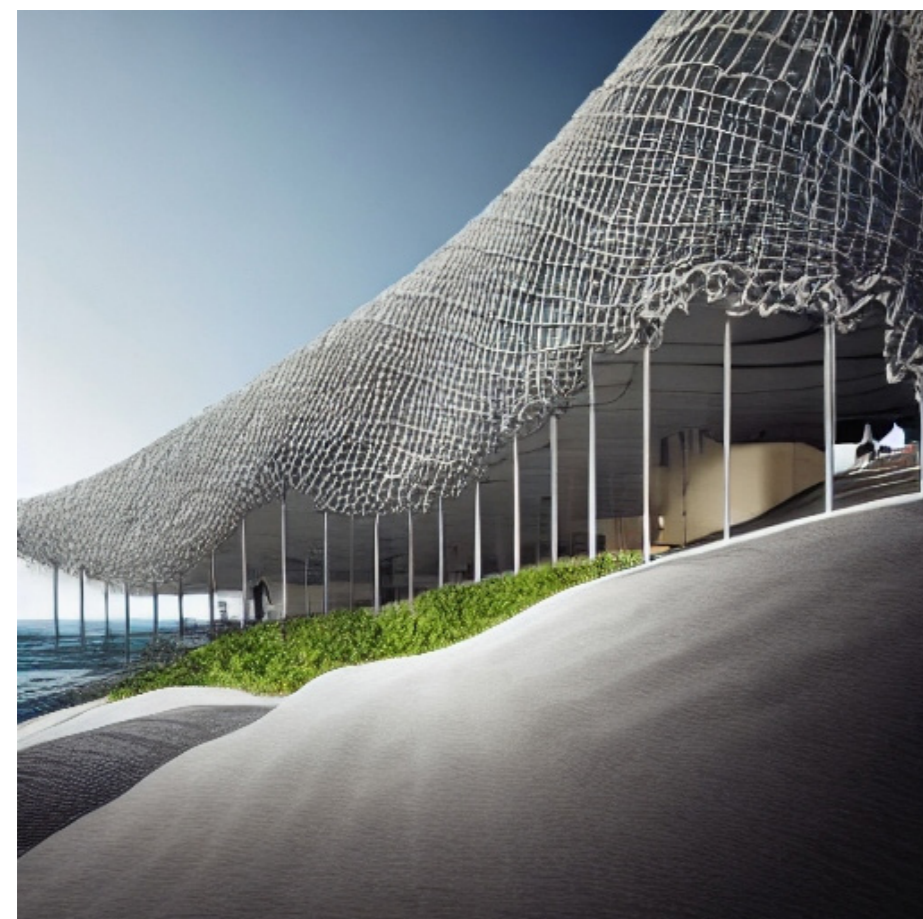
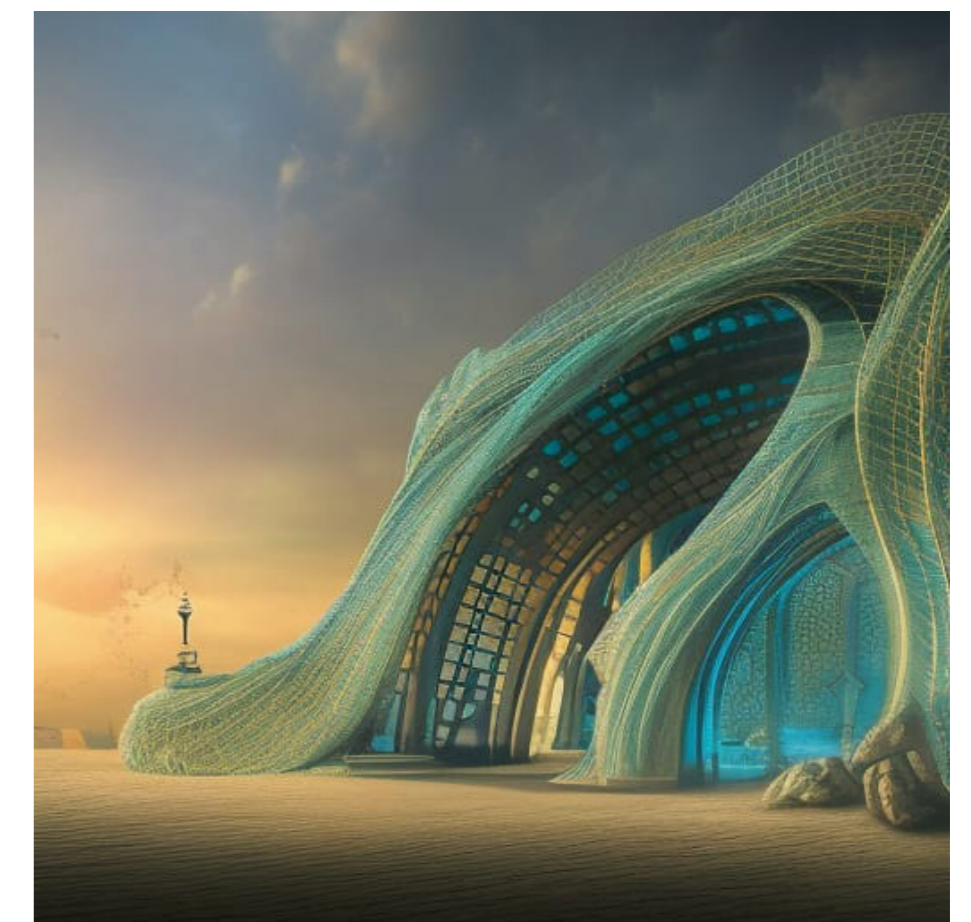
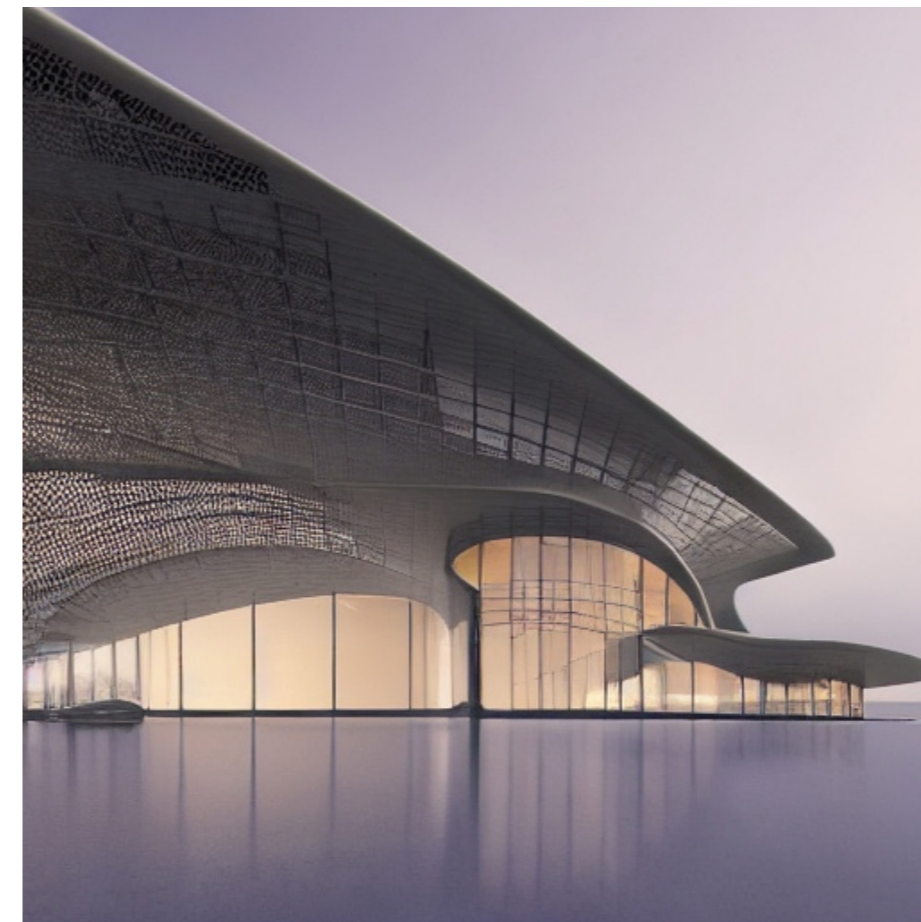
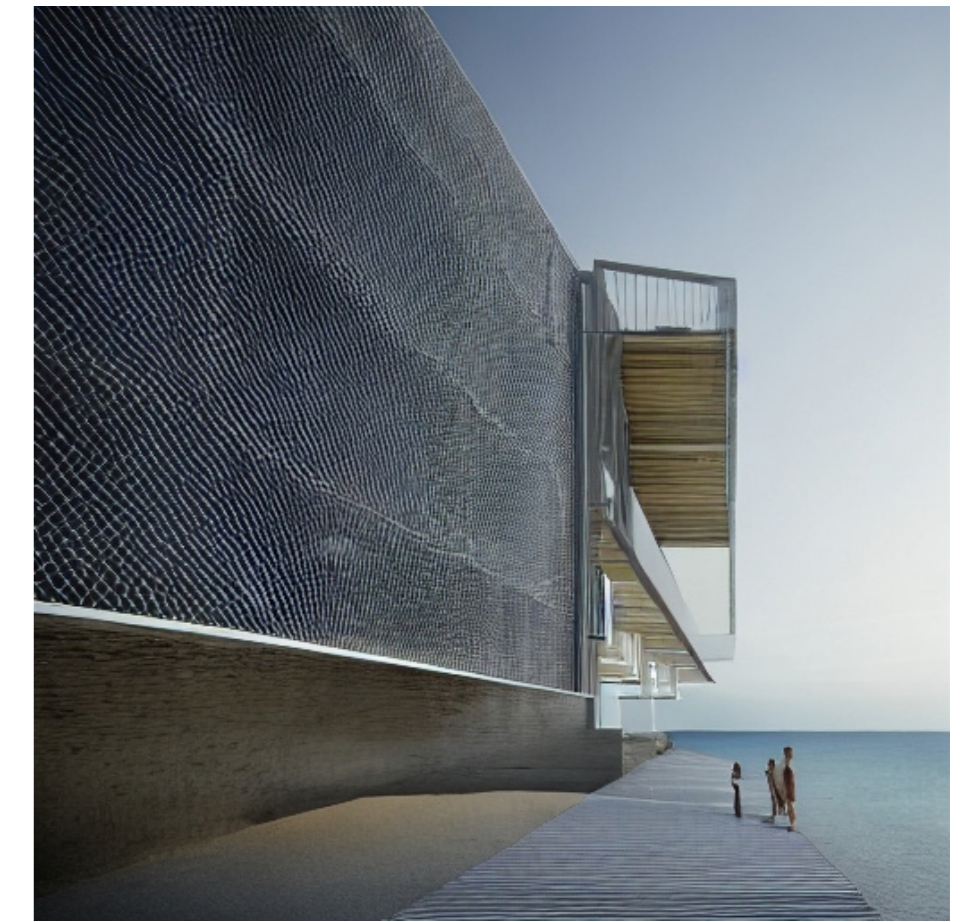

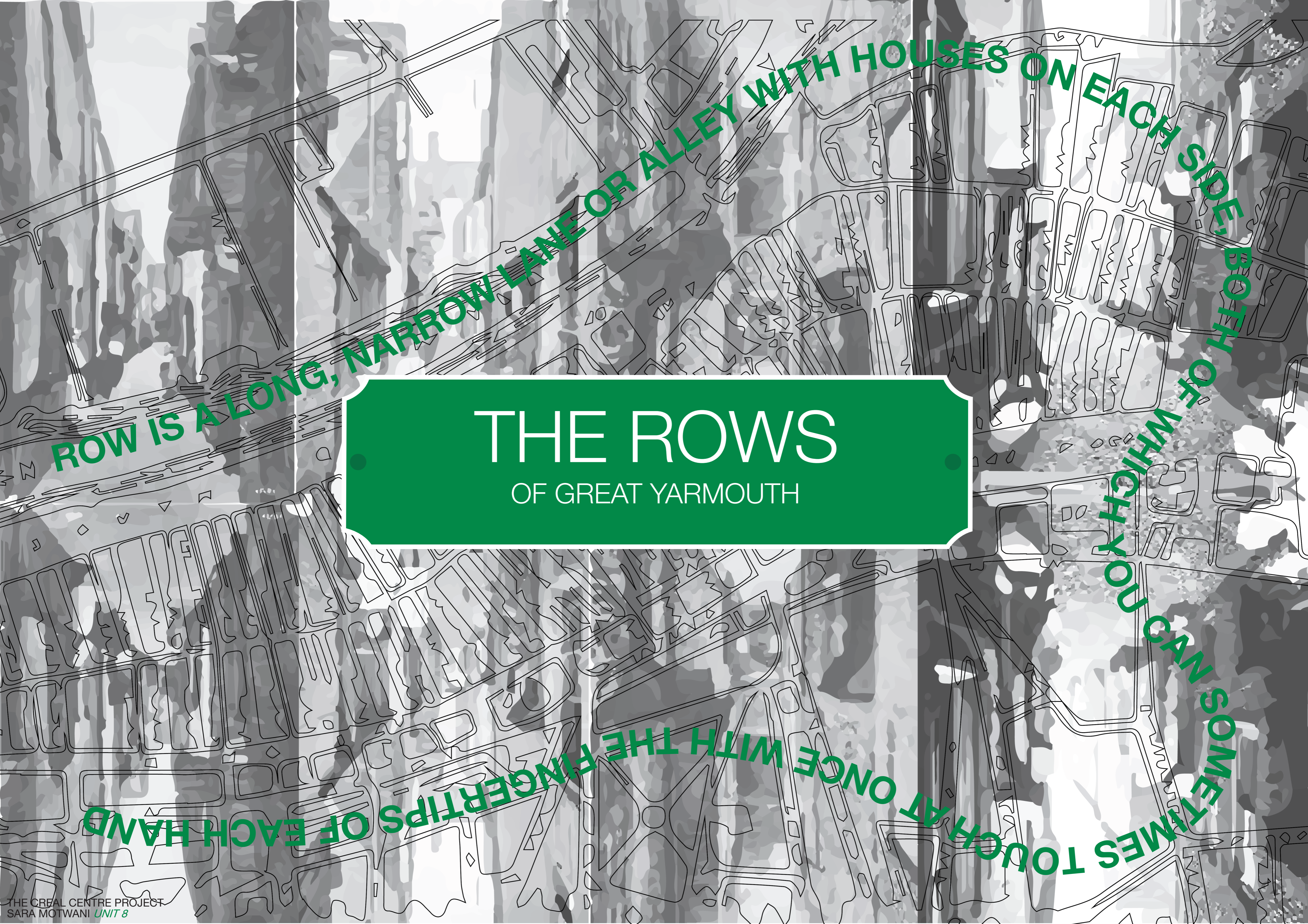

ROW IS A LONG, NARROW LANE OR ALLEY WITH HOUSES ON EACH SIDE, BOTH OF WHICH YOU CAN SOMETIMES TOUCH AT ONCE WITH THE FINGERTIPS OF EACH HAND

THE ROWS

OF GREAT YARMOUTH



SITE+INITIAL MASSING



SOILSSCAPE SAND DUNE SOIL TEXTURE SANDY DRAINAGE FREELY DRAINING DRAINS TO GROUNDWATER FERTILITY LIME-RICH

SPACE TYPE	ART GALLERY	ARTIST STUDIO	ARTISTS LOUNGE	1-1 THERAPY ROOM	GROUP THERAPY ROOM	LOUNGE
MINIMUM SIZE	100 m ²	15 m ²	20 - 25 m ²	7 m ²	12 m ²	20 - 25 m ²
OPTIMUM SIZE	200 - 400 m ²	25 - 30 m ²	60 - 80 m ²	9 - 12 m ²	15 - 20 m ²	60 - 80 m ²
CEILING HEIGHT	3.0 - 4.5 m ²	2.7 - 3.0 m ²	2.4 - 3.0 m ²	2.7 - 3.0 m ²	2.7 - 3.0 m ²	2.4 - 3.0 m ²

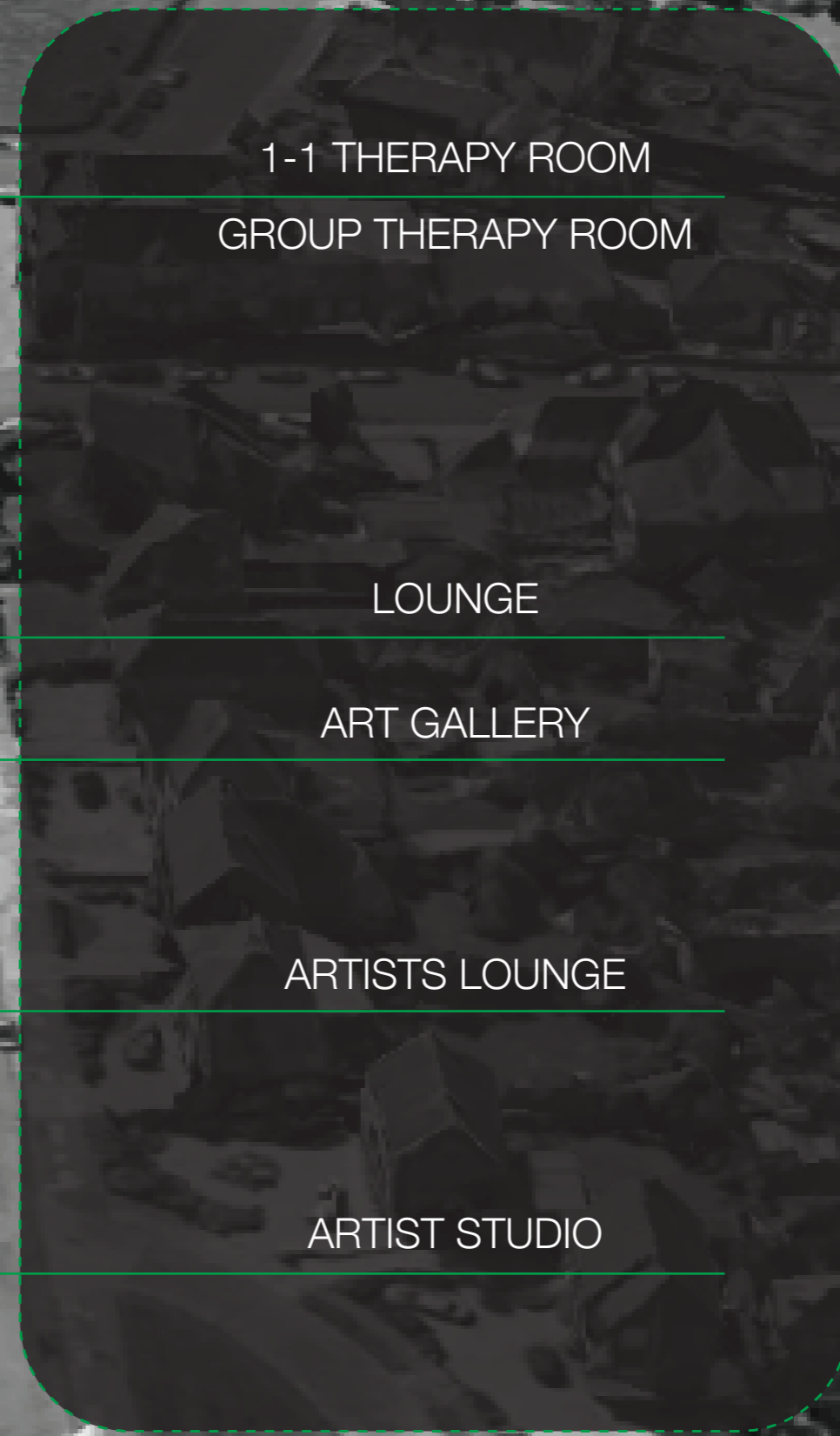
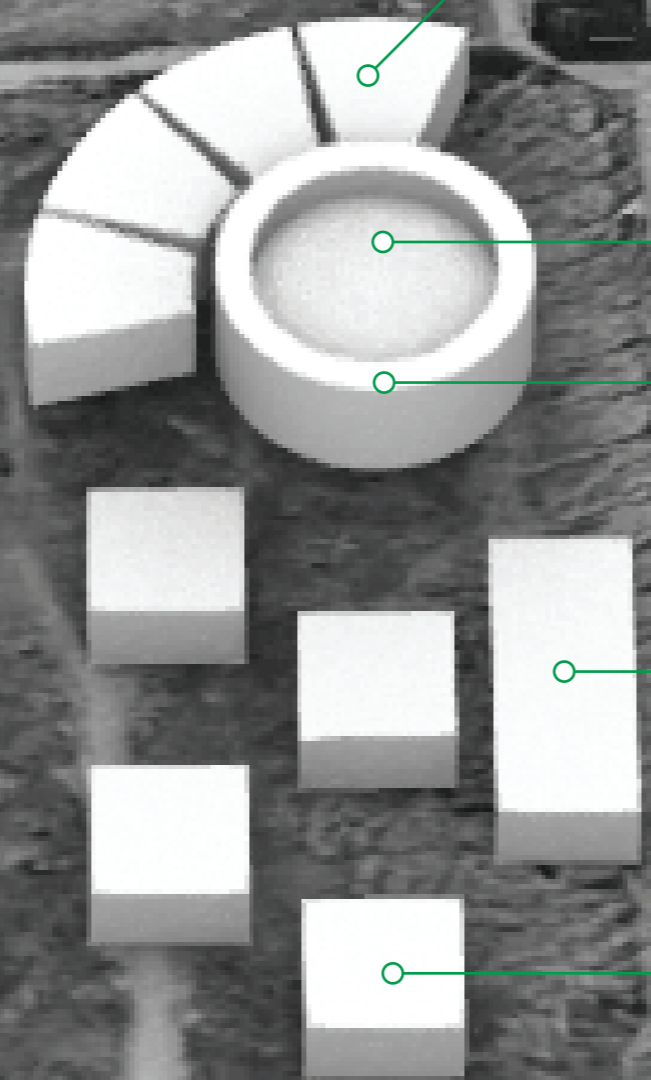

ARRANGEMENT 1

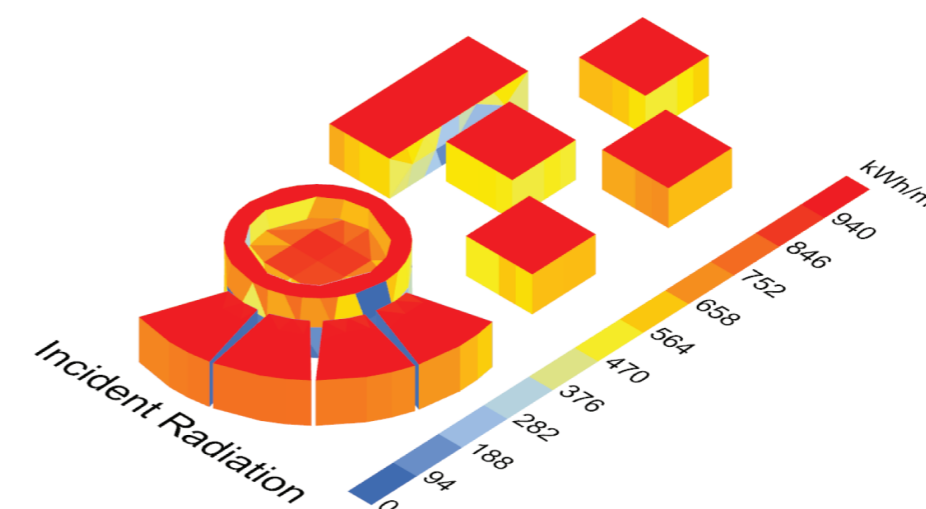
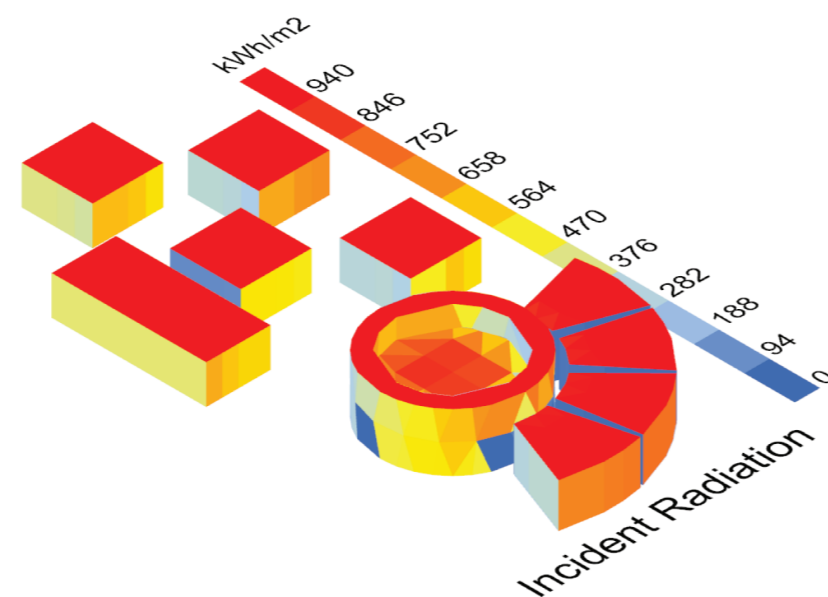
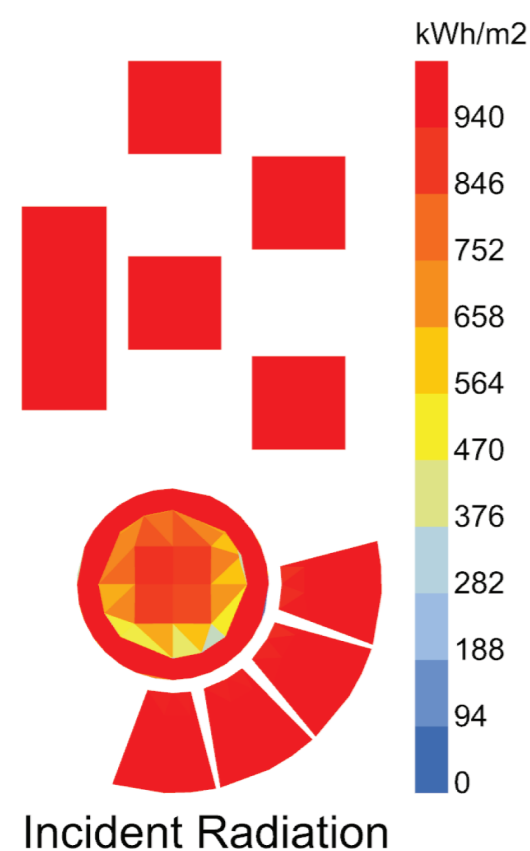

ARRANGEMENT 2

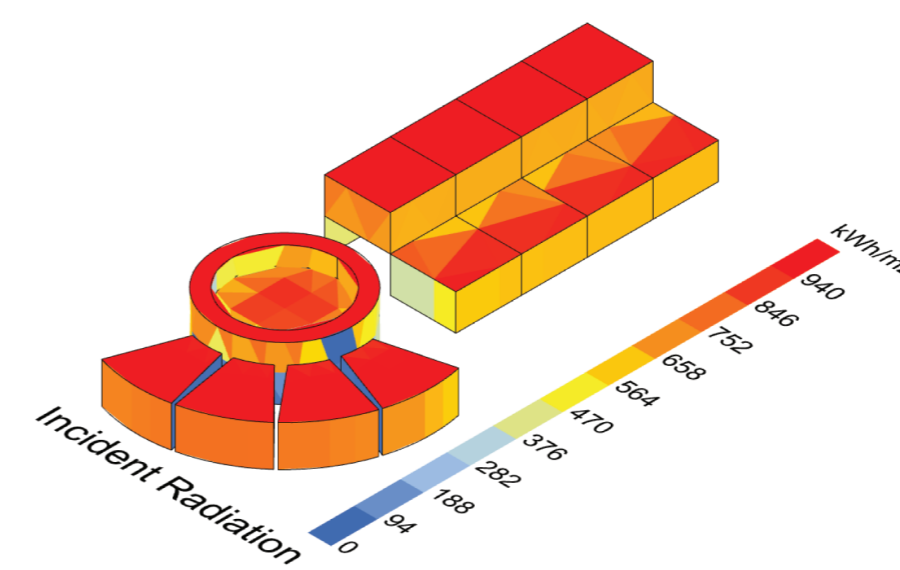
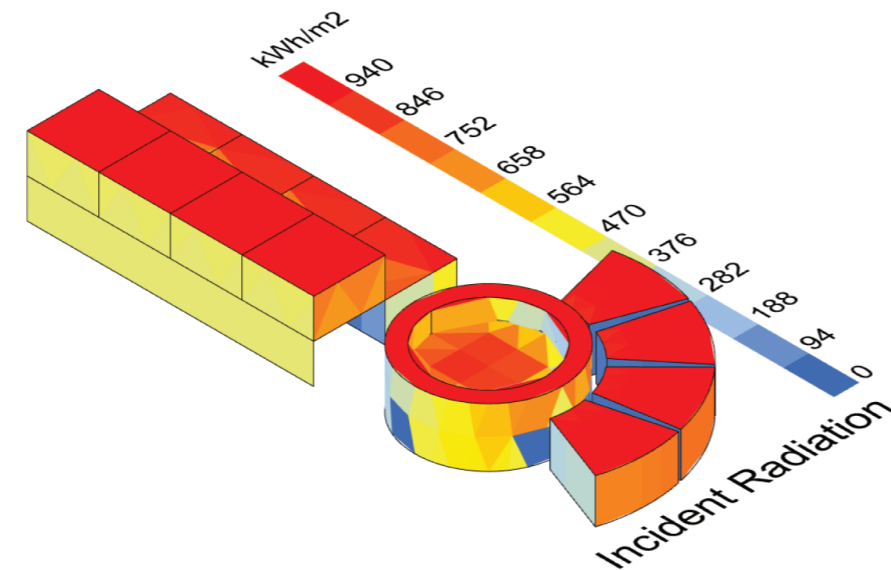
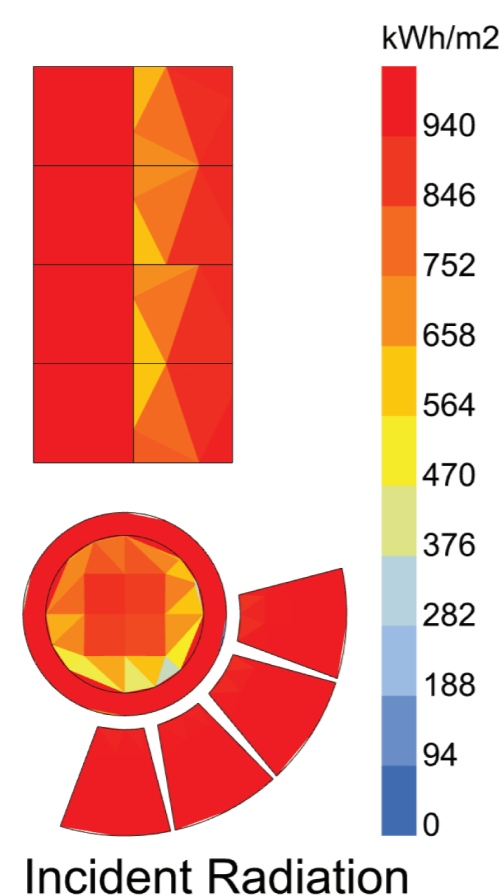

ARRANGEMENT 3

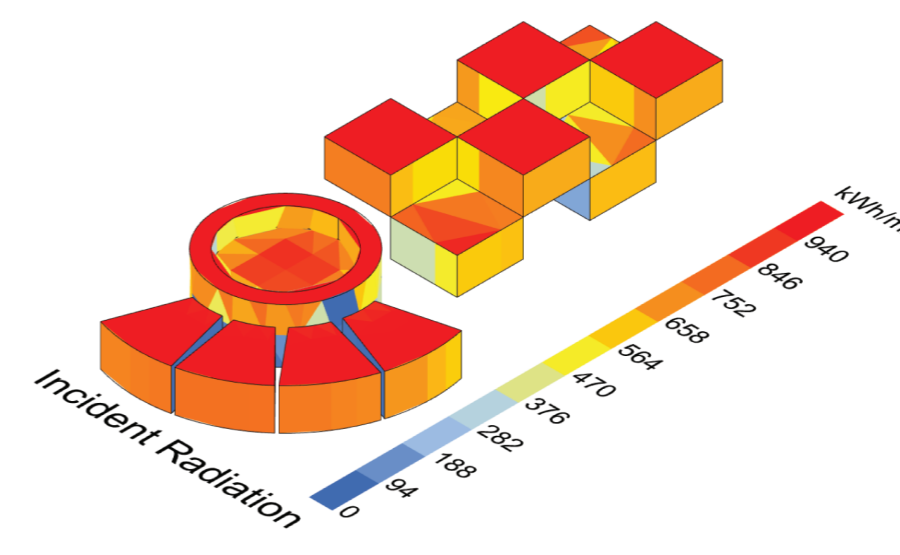
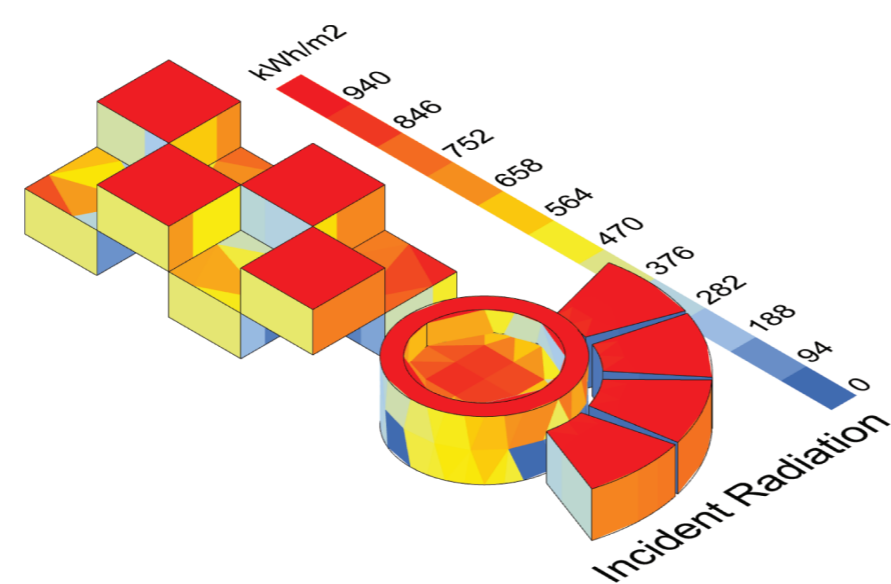
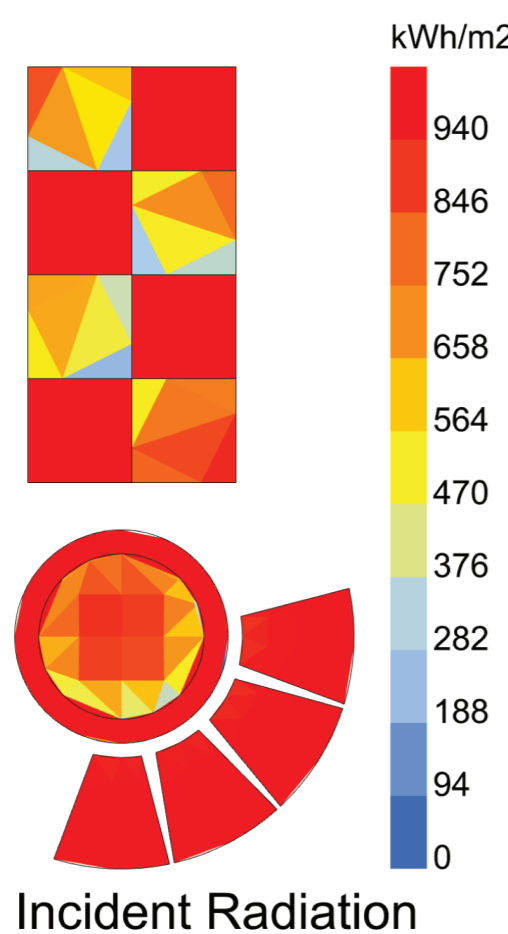

- **INITIAL GOAL:** MAXIMISE GLAZING THROUGH WINDOWS AND SKYLIGHTS TO PROVIDE NATURAL LIGHT + VIEWS OF THE OCEAN

- **CONSIDERATIONS:**
 - STUDIOS MUST NOT BLOCK THE VIEW OF EACH OTHER.
 - WHEREVER POSSIBLE, STUDIOS SHOULD BE ORIENTED TO PROVIDE SHADING TO EACH OTHER.

- **ENVIRONMENTAL FACTORS:**
 - SINCE SPACE WILL HAVE MAXIMISED GLAZING, ORIENTATION SHOULD HELP PROVIDE AS MUCH SHADING AS POSSIBLE.
 - INCIDENT RADIATION STUDIES ARE CONDUCTED TO ASSESS THE SOLAR IMPACT ON VARIED ORIENTATIONS.
 - IT IS IMPORTANT TO PREVENT OVERHEATING OF THE STUDIOS DUE TO SOLAR HEAT GAINS IN ORDER TO MAINTAIN INDOOR COMFORT CONDITIONS.

- **RESULT OF THE STUDY:** THE FINAL ITERATION, PROVIDES THE MOST EFFICIENT ORIENTATION OF THE ARTIST STUDIOS. THE STUDIOS DON'T OBSTRUCT THE OCEANIC VIEW OF EACH OTHER WHILE ALSO PROVIDING MAXIMUM SHADING TO EACH OTHER.

1-1 THERAPY ROOM

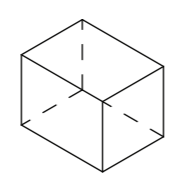

GROUP THERAPY ROOM

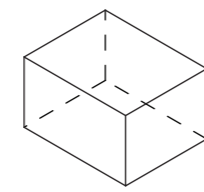

ART GALLERY

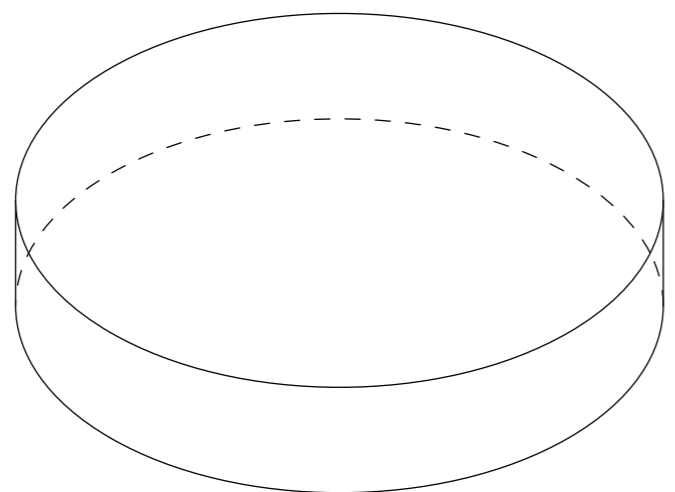

ARTIST STUDIO

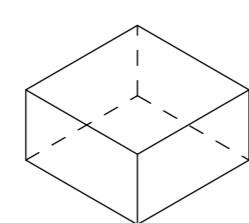

ARTISTS LOUNGE

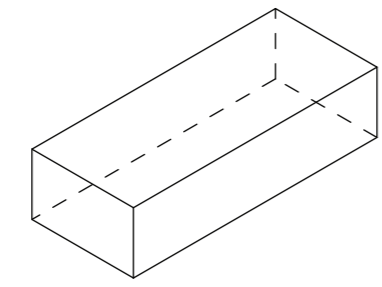

LOUNGE

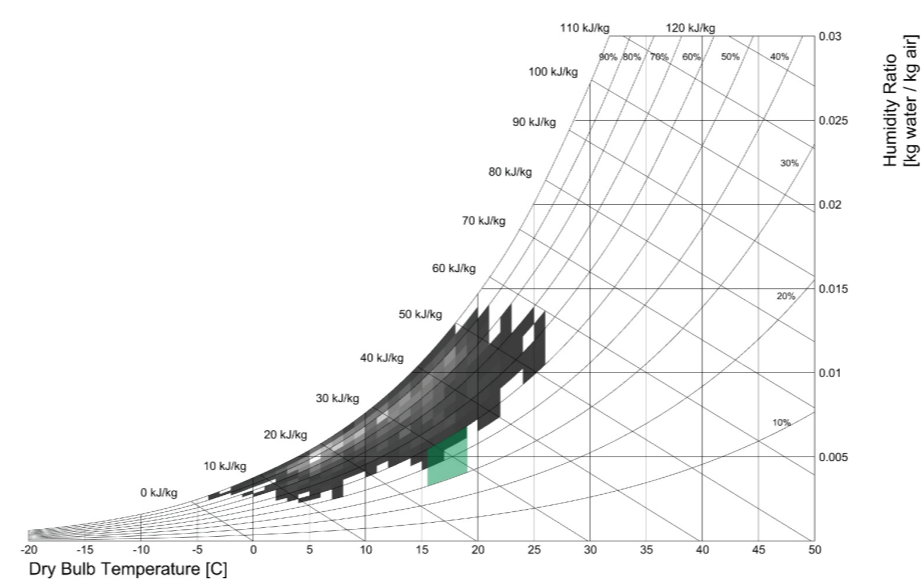
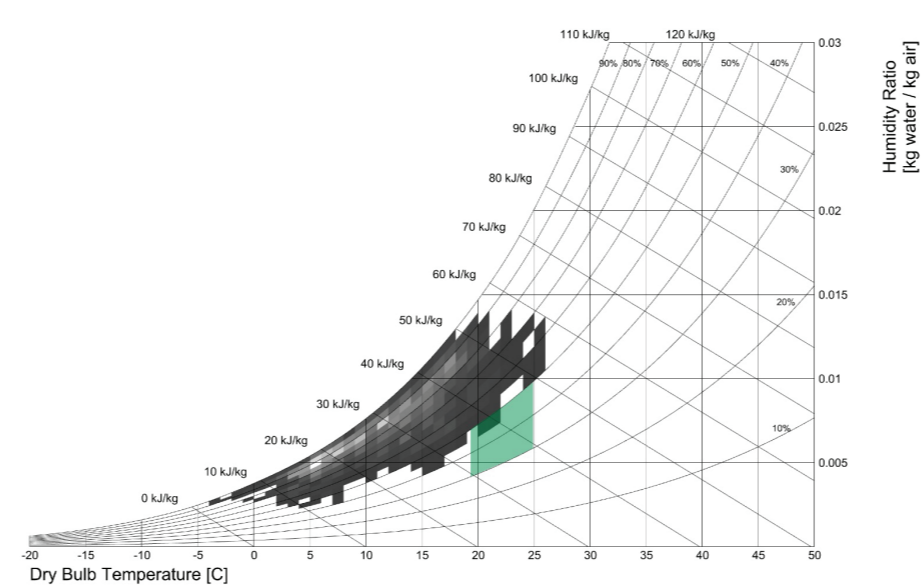
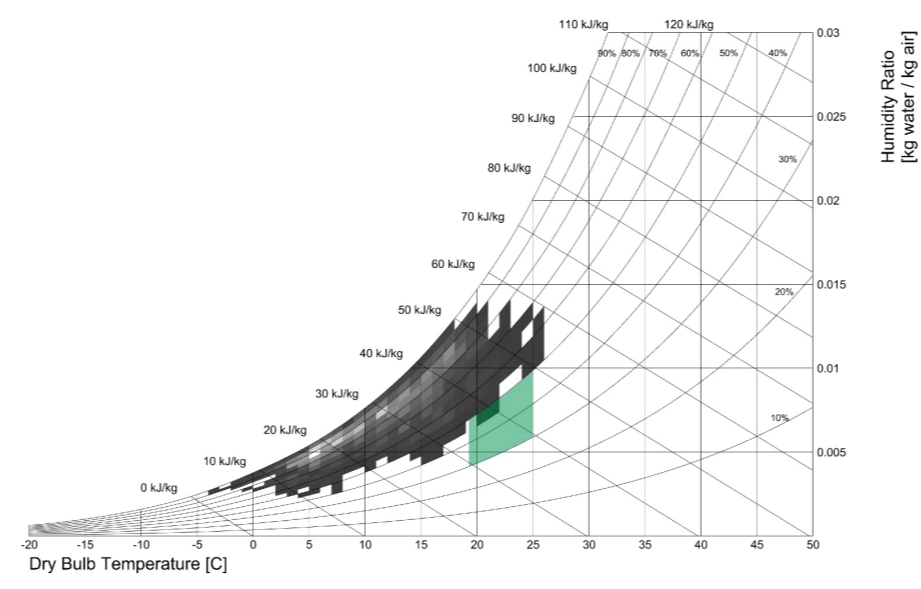
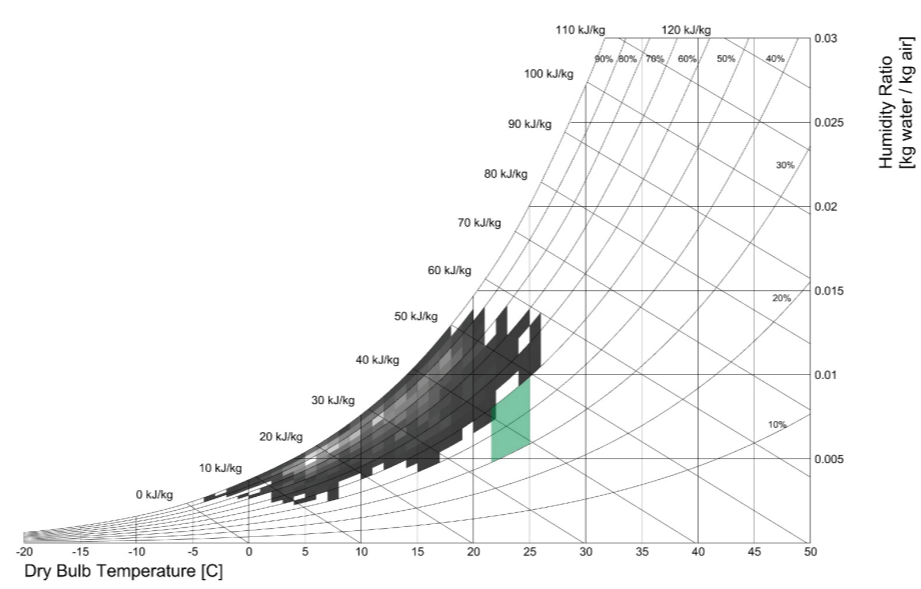
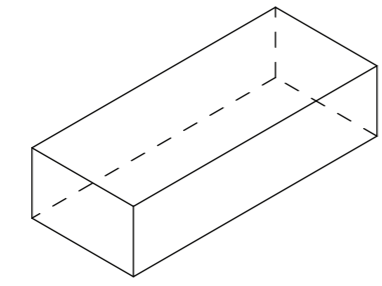

SPECIFIC COMFORT CONDITIONS REQUIRED IN THE SPECIFIED SPACE

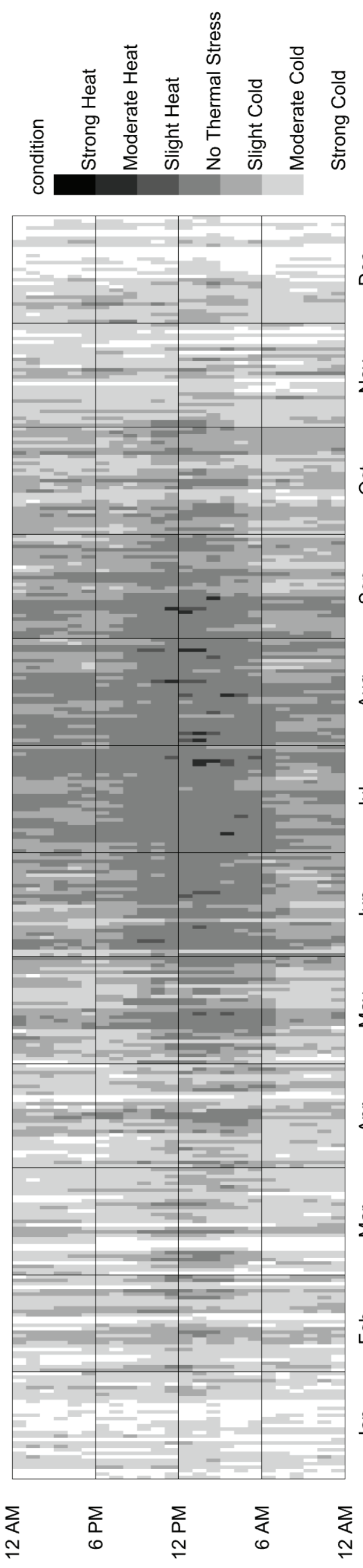
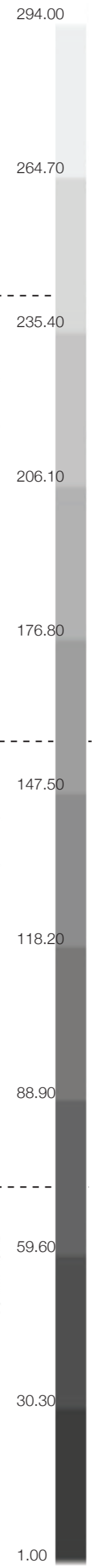



FORM FINDING

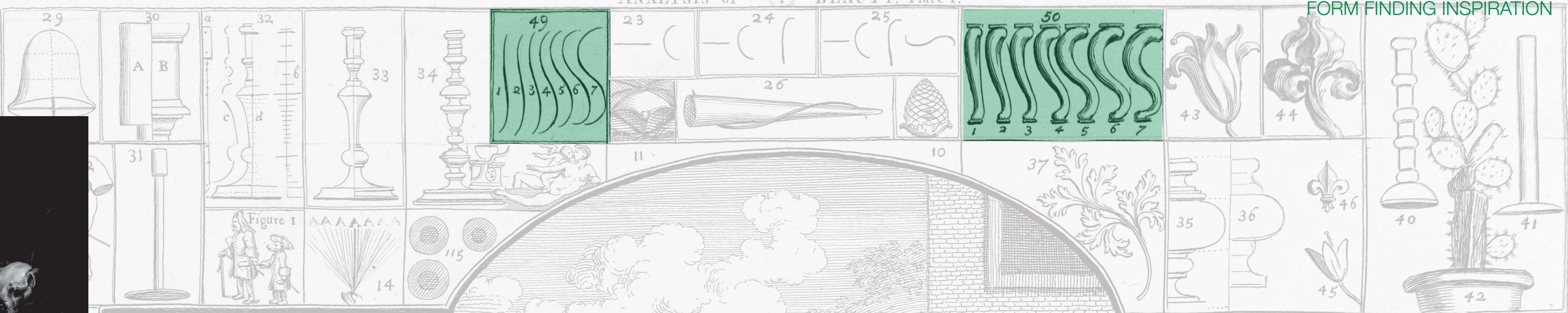

WILLIAM HOGARTH



ANALYSIS OF BEAUTY

LINES OF BEAUTY

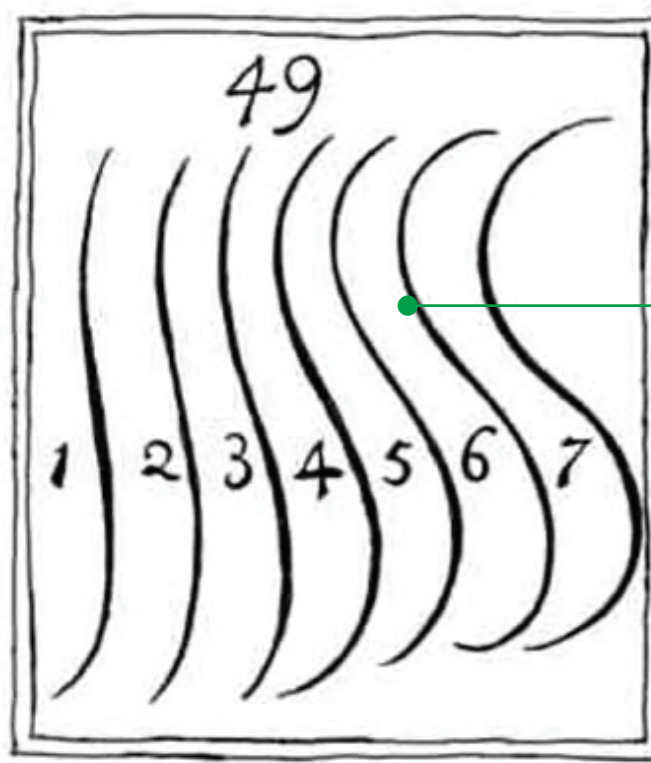
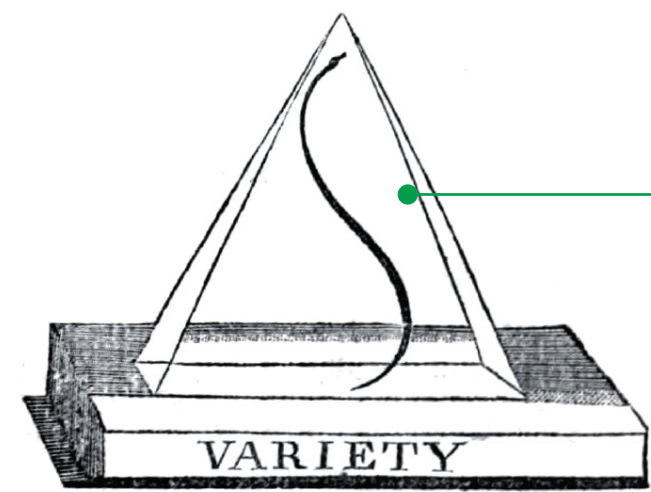

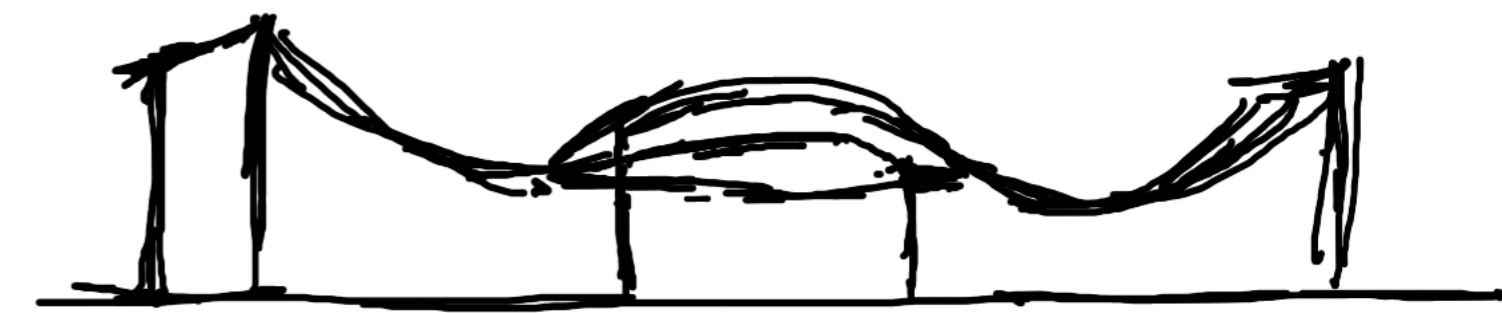
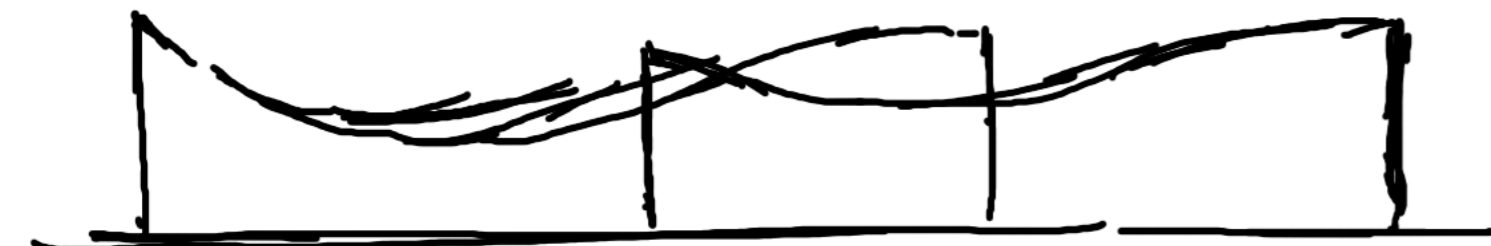
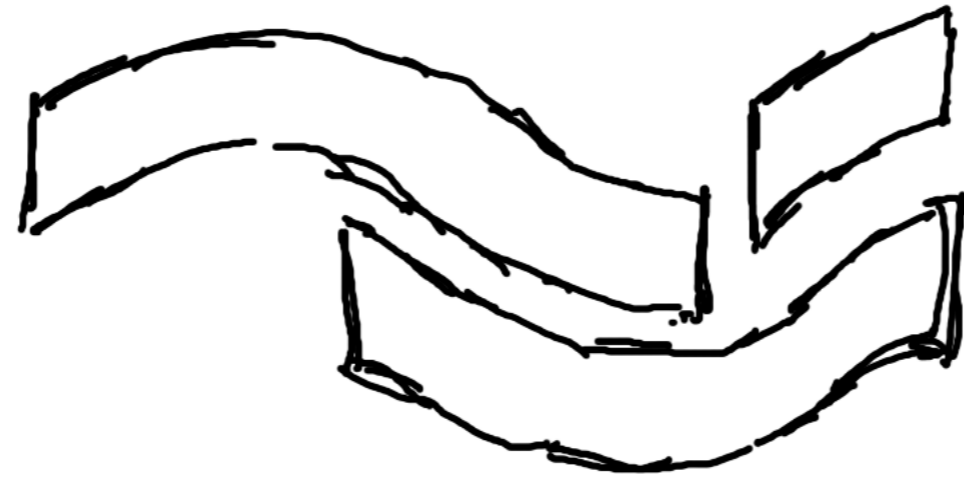
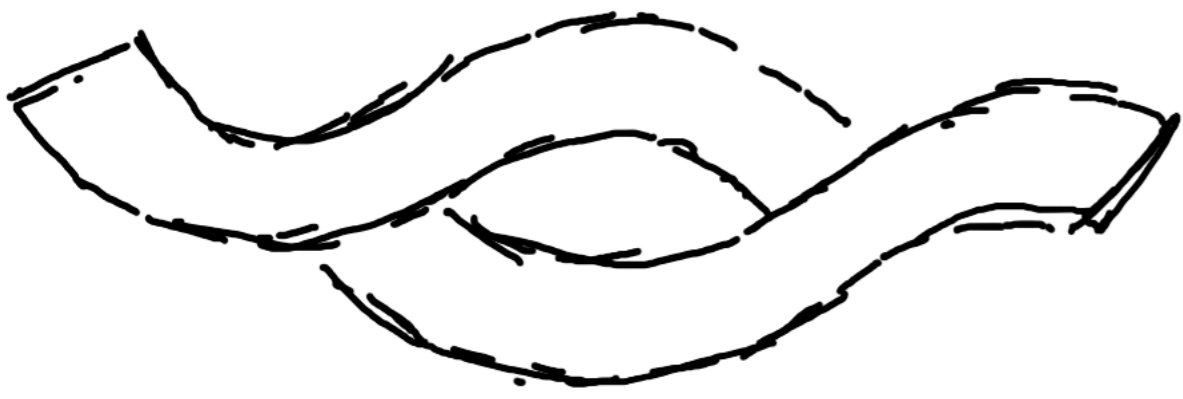

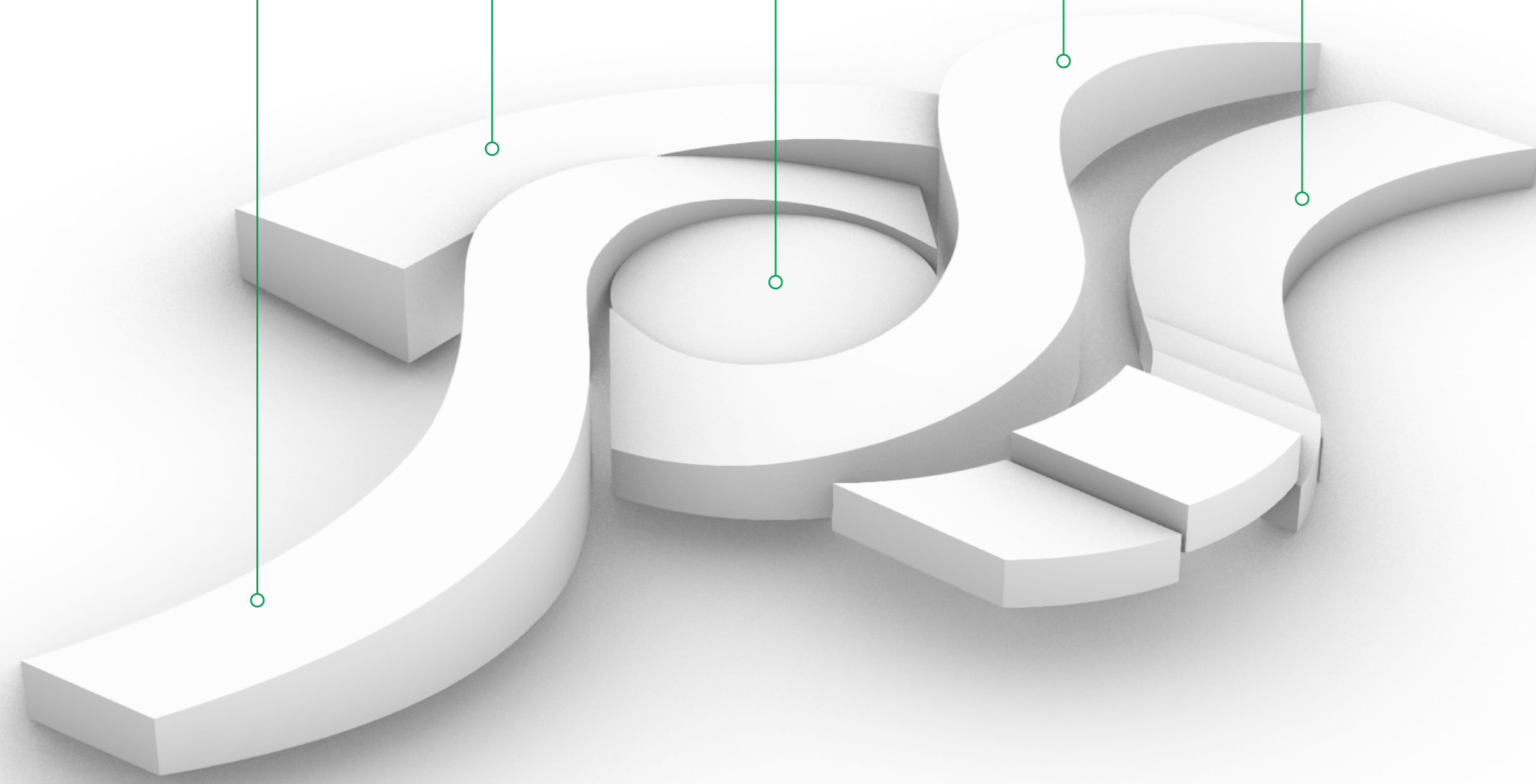
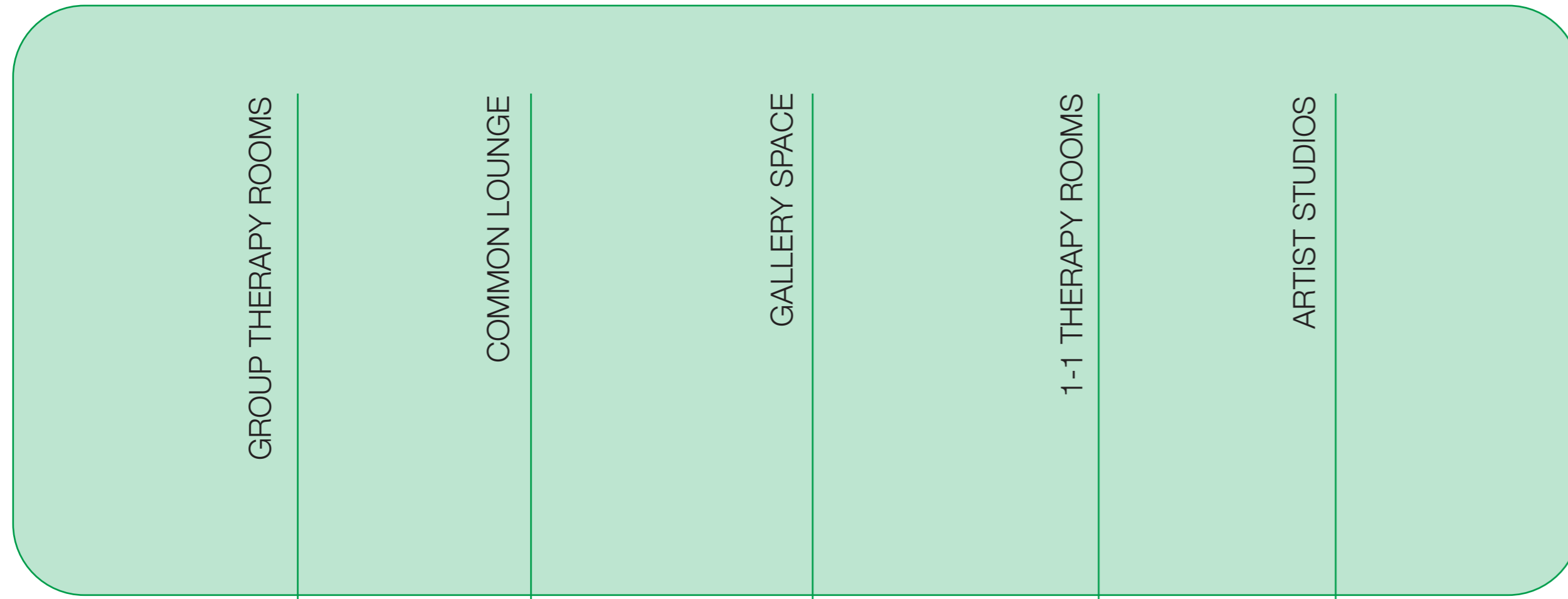

INCIDENT RADIATION STUDY

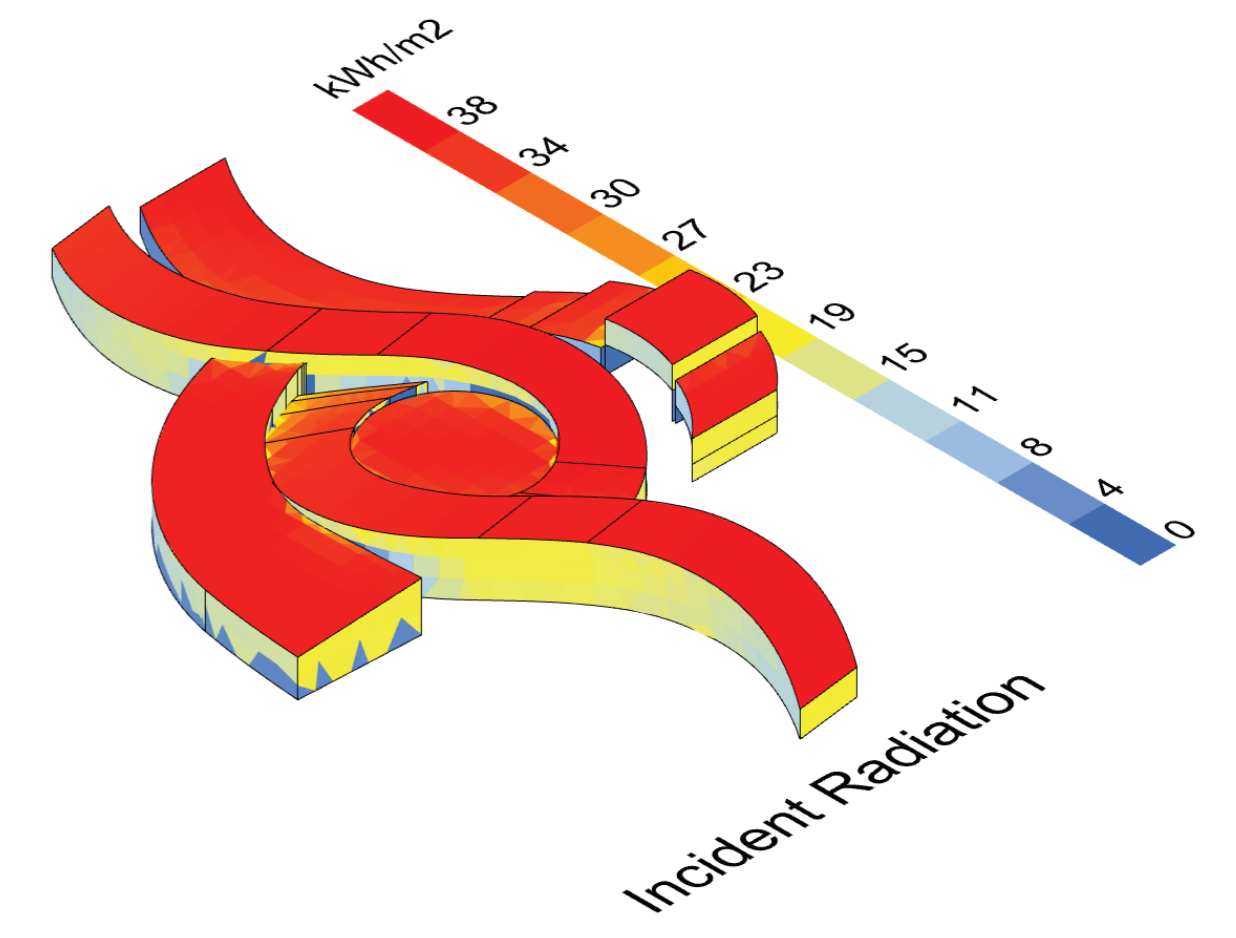
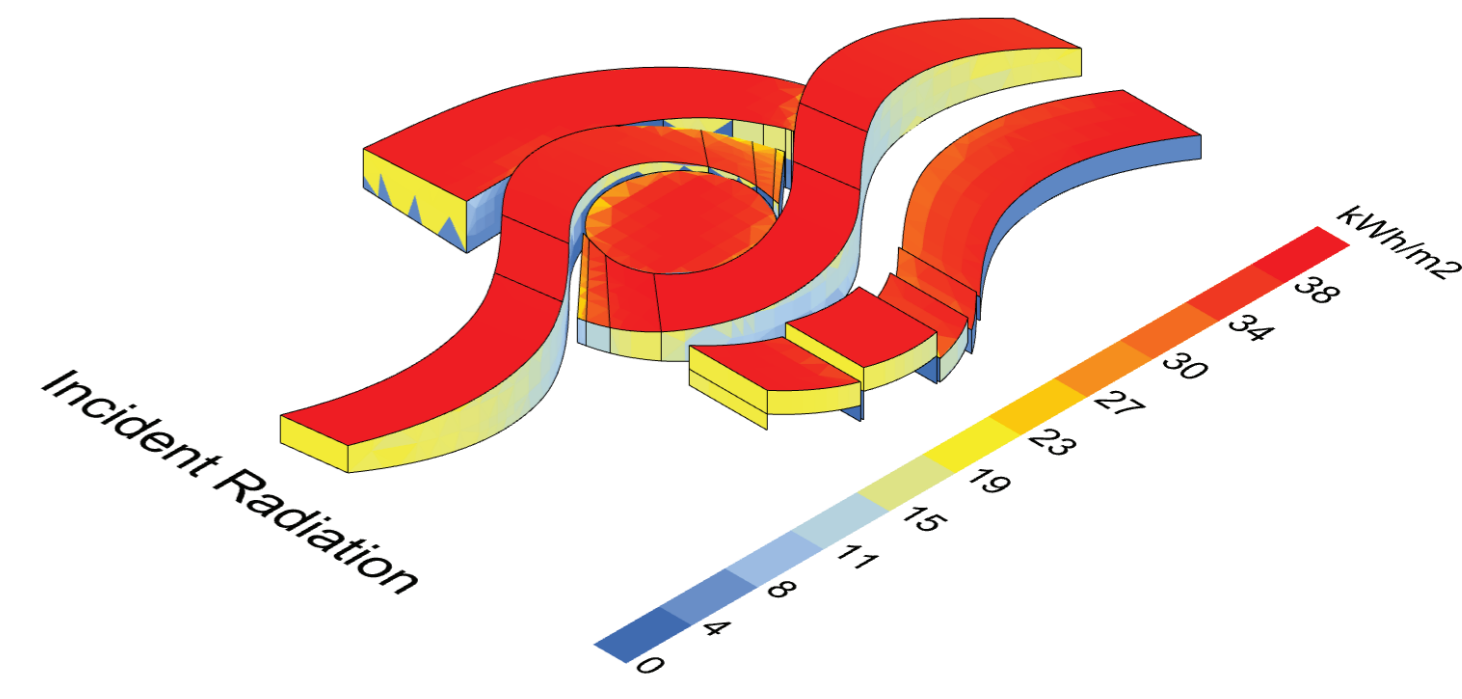
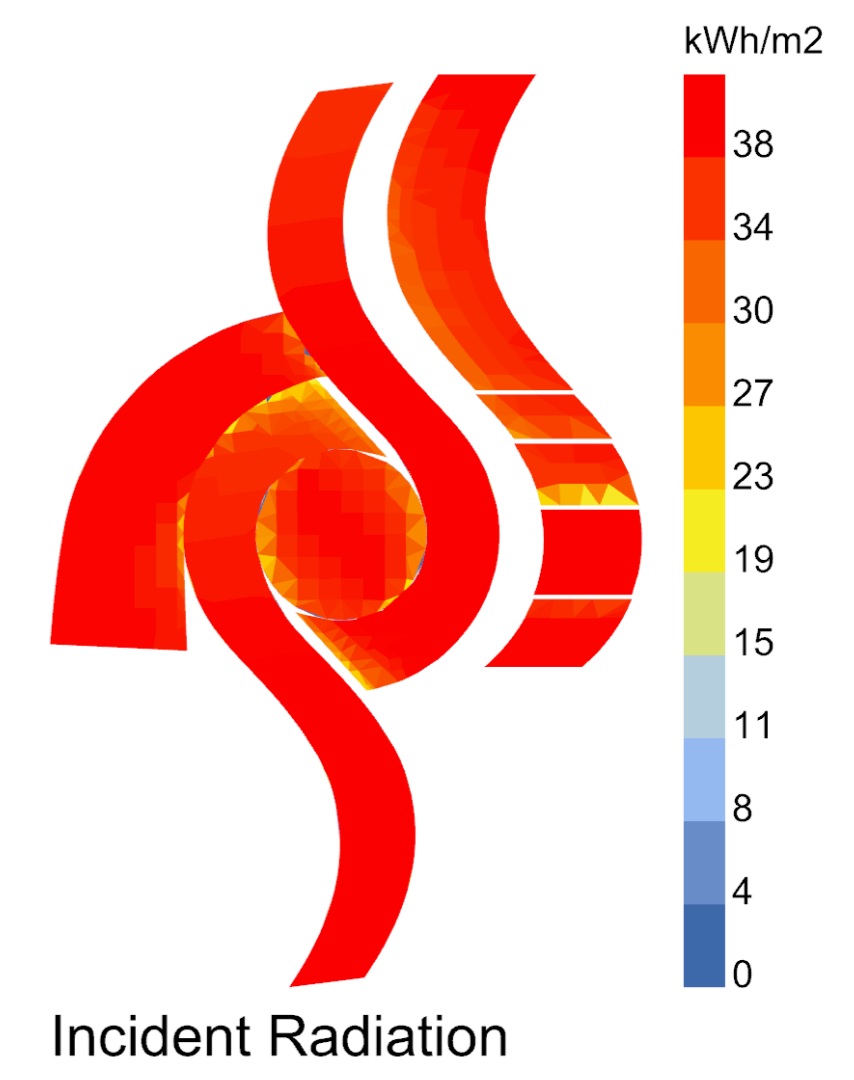

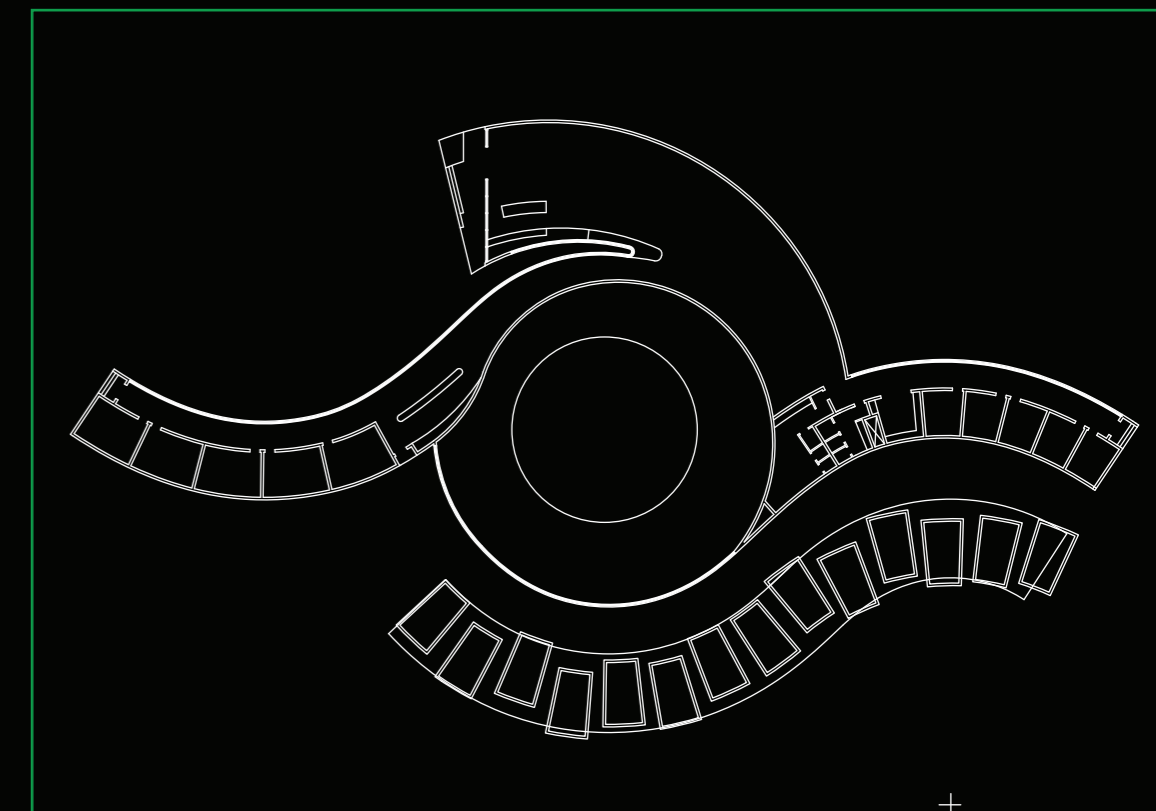
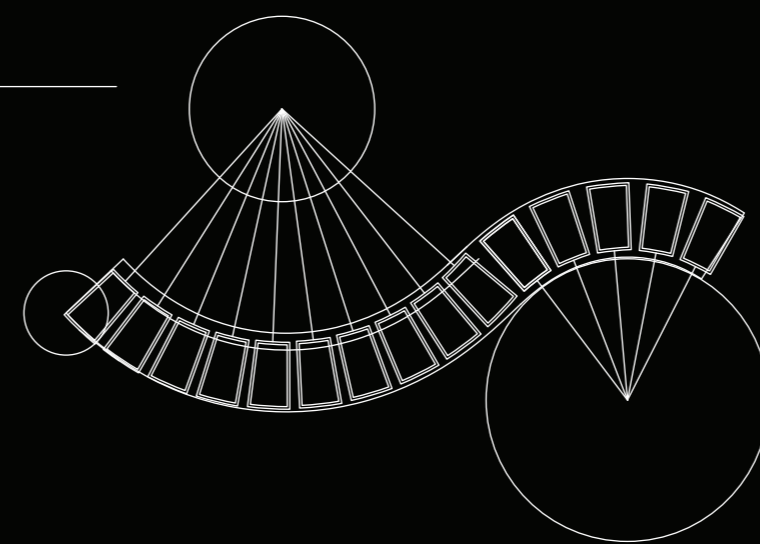
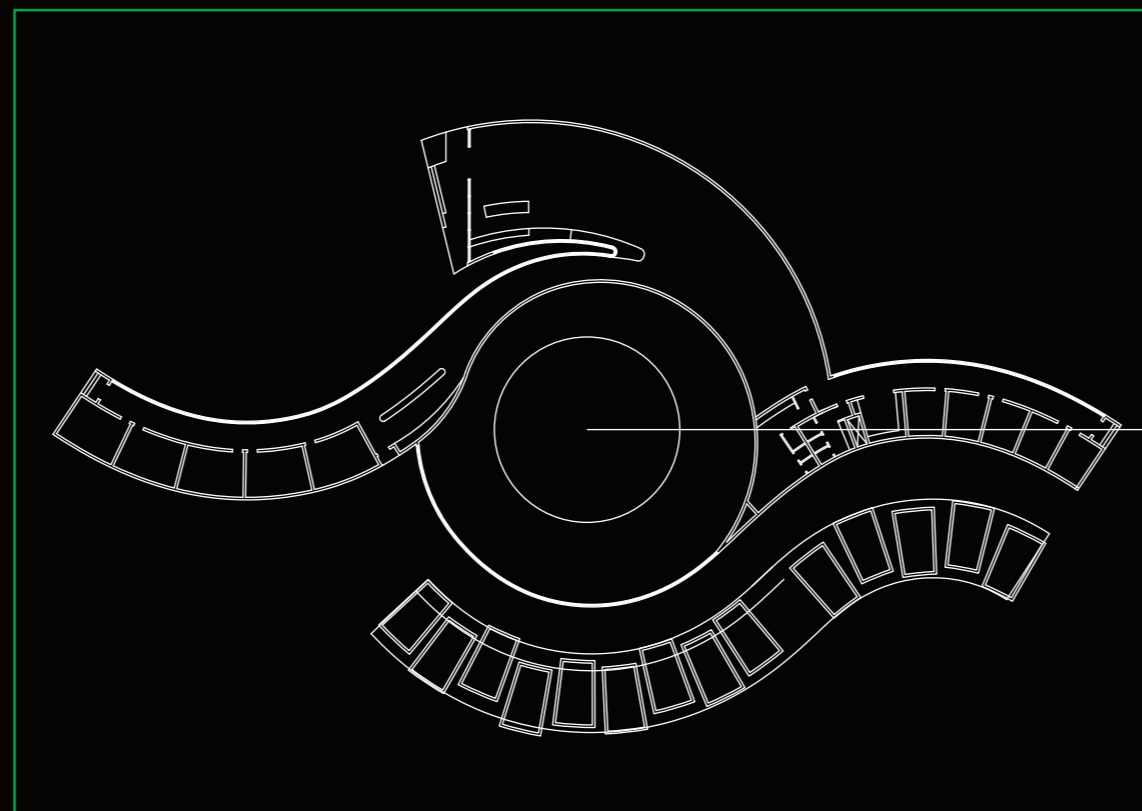
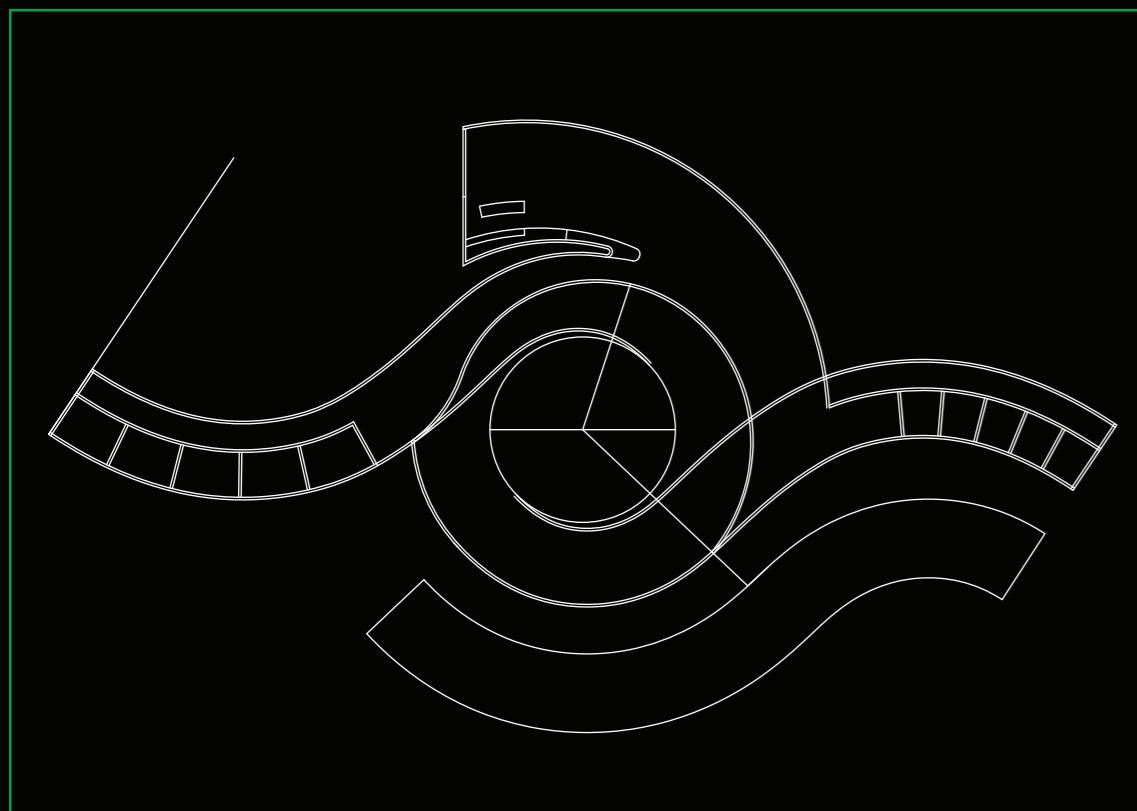
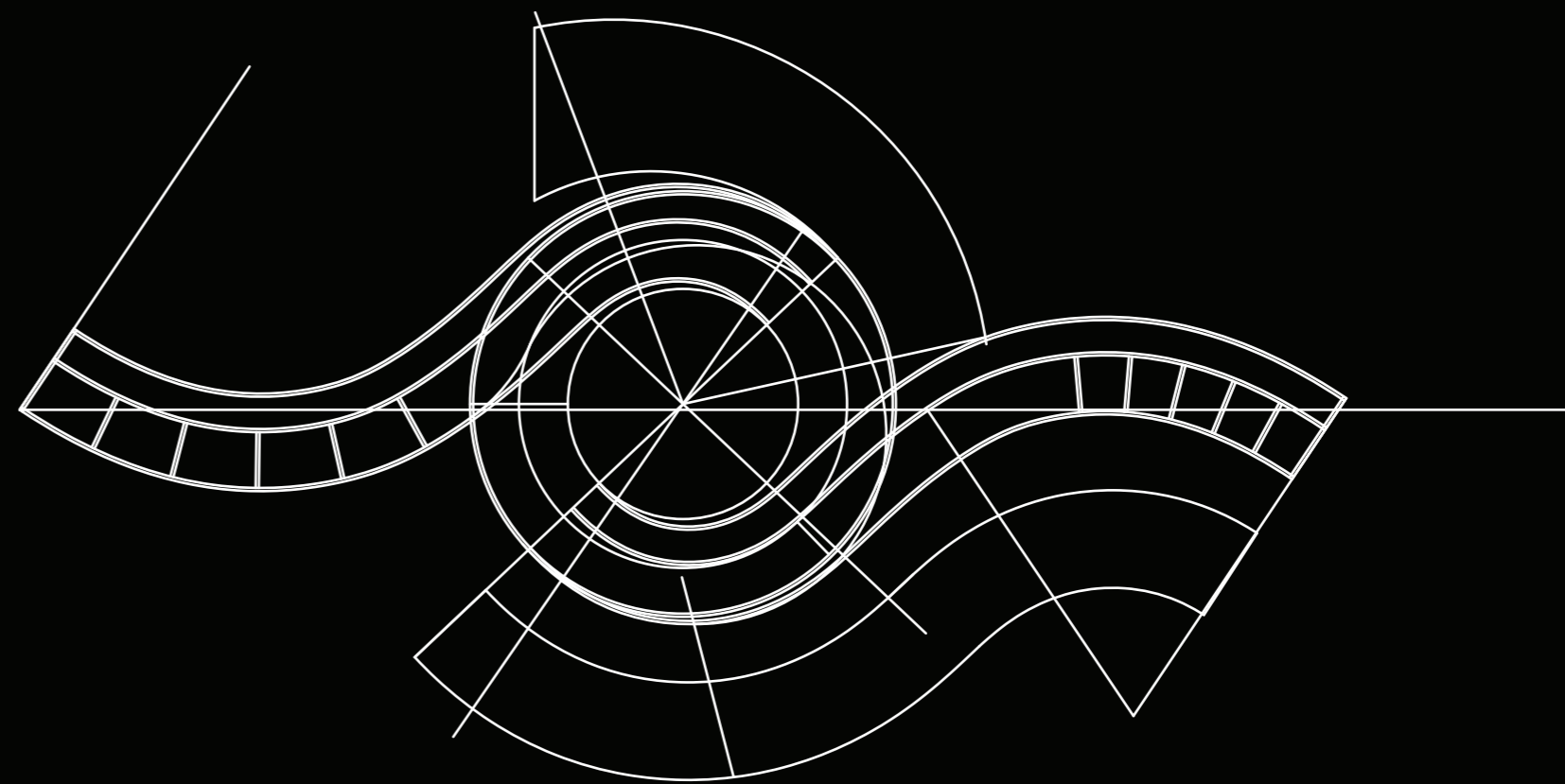
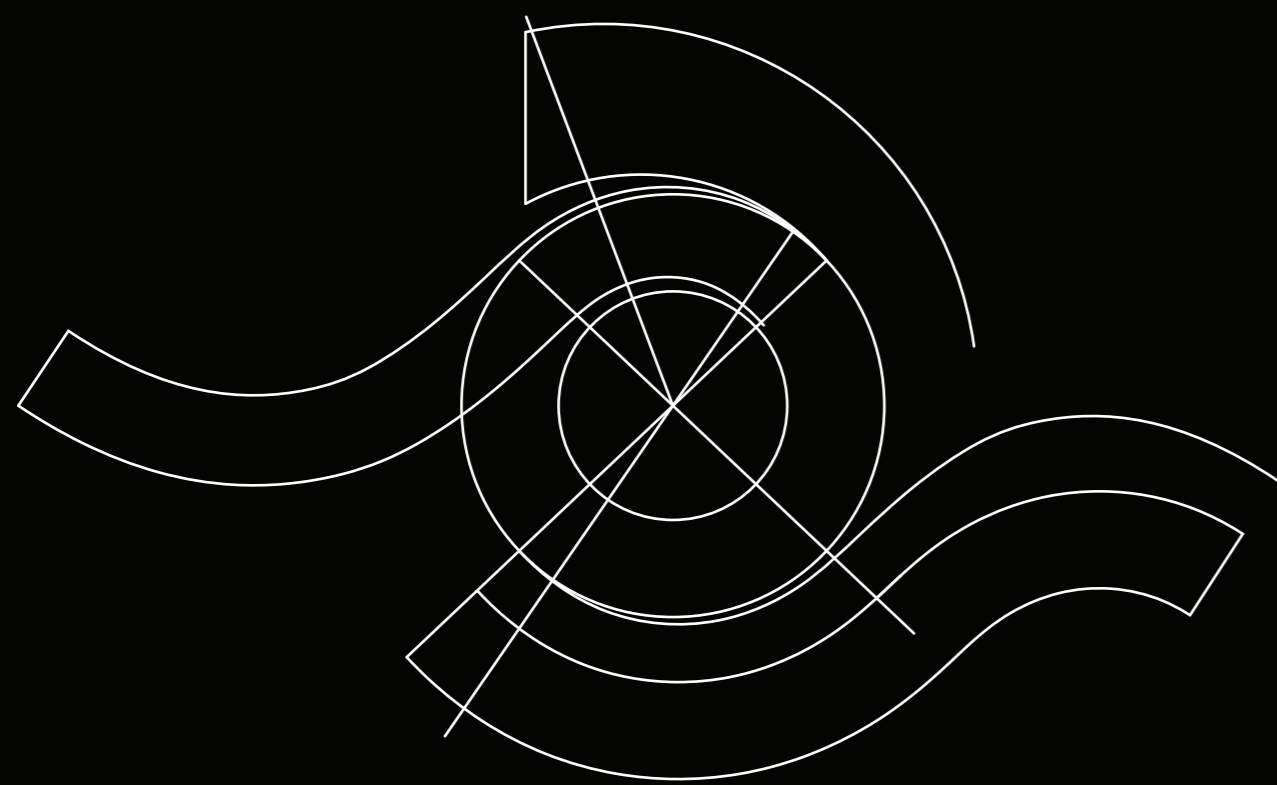
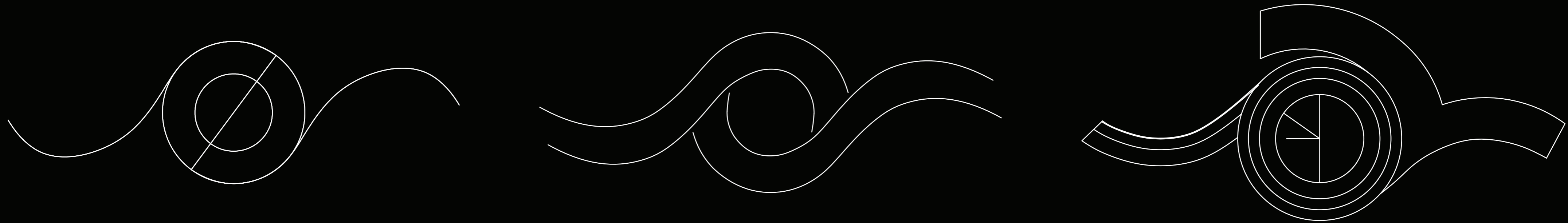



FIRST ITERATION



ROOF PLAN ON SITE

1:150

THE CREAL CENTRE PROJECT
SARA MOTWANI *UNIT 8*



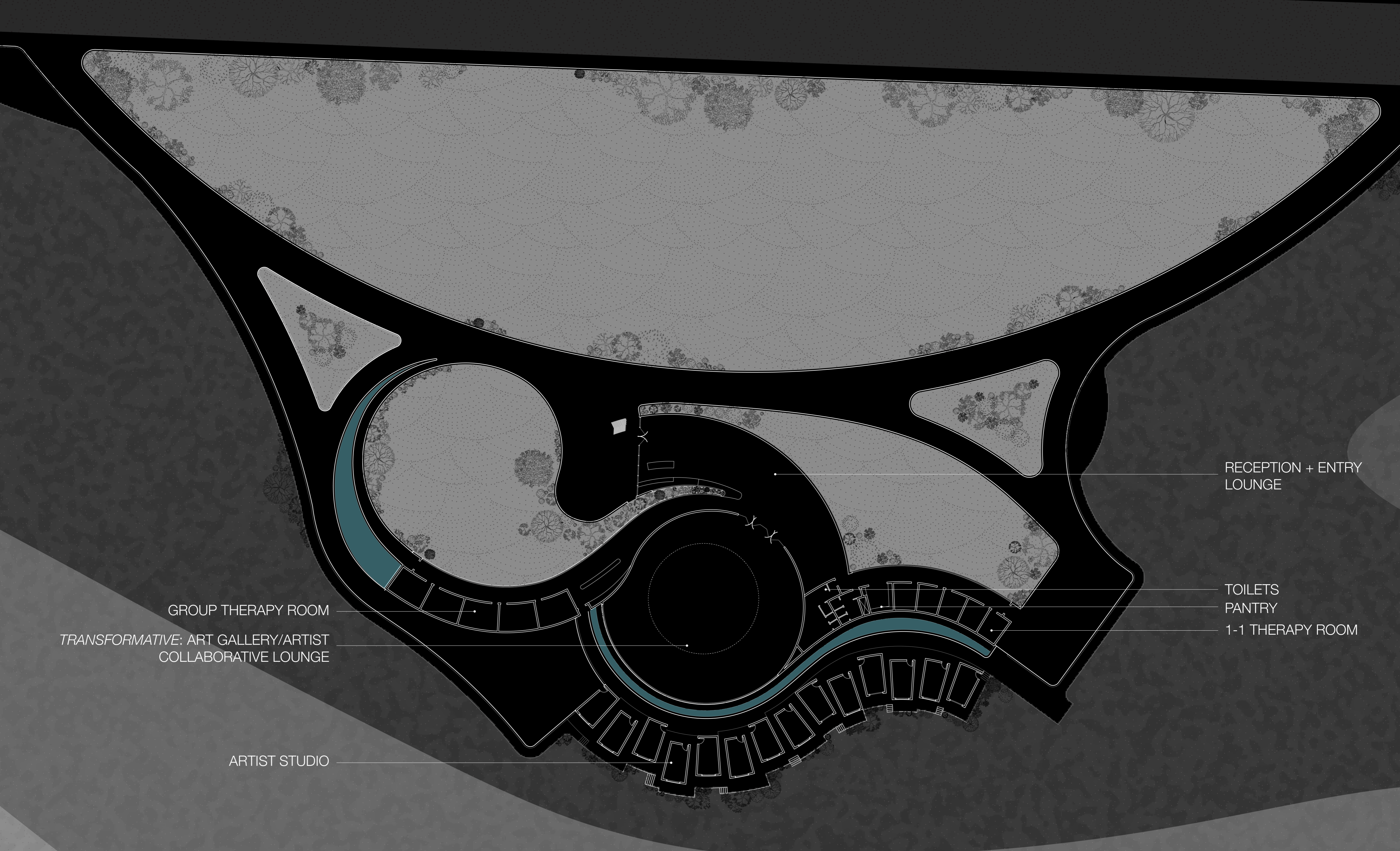

GROUP THERAPY ROOM
TRANSFORMATIVE: ART GALLERY/ARTIST
COLLABORATIVE LOUNGE

ARTIST STUDIO

RECEPTION + ENTRY
LOUNGE

TOILETS
PANTRY
1-1 THERAPY ROOM

FLOOR PLAN ON SITE

1:200
THE CREAL CENTRE PROJECT
SARA MOTWANI *UNIT 8*



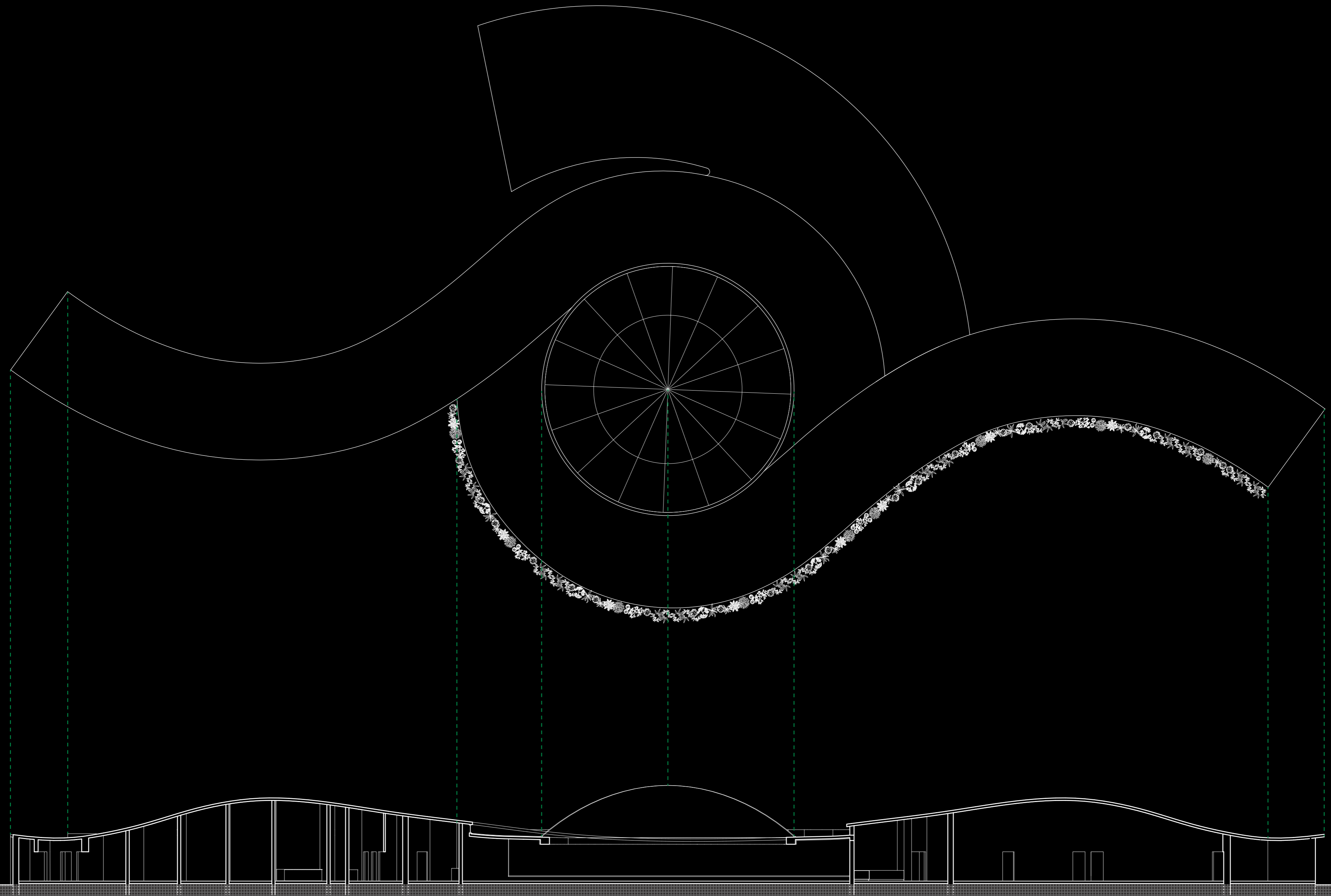

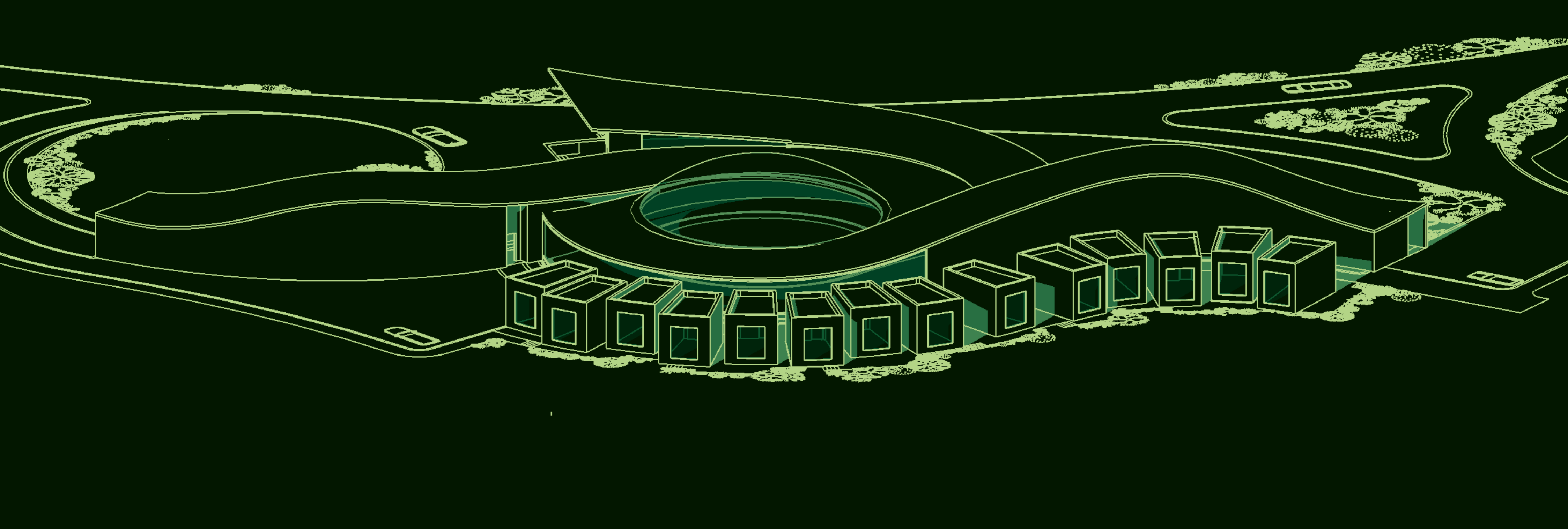

WEST (TOP) AND EAST (BOTTOM) PERSPECTIVE VIEWS

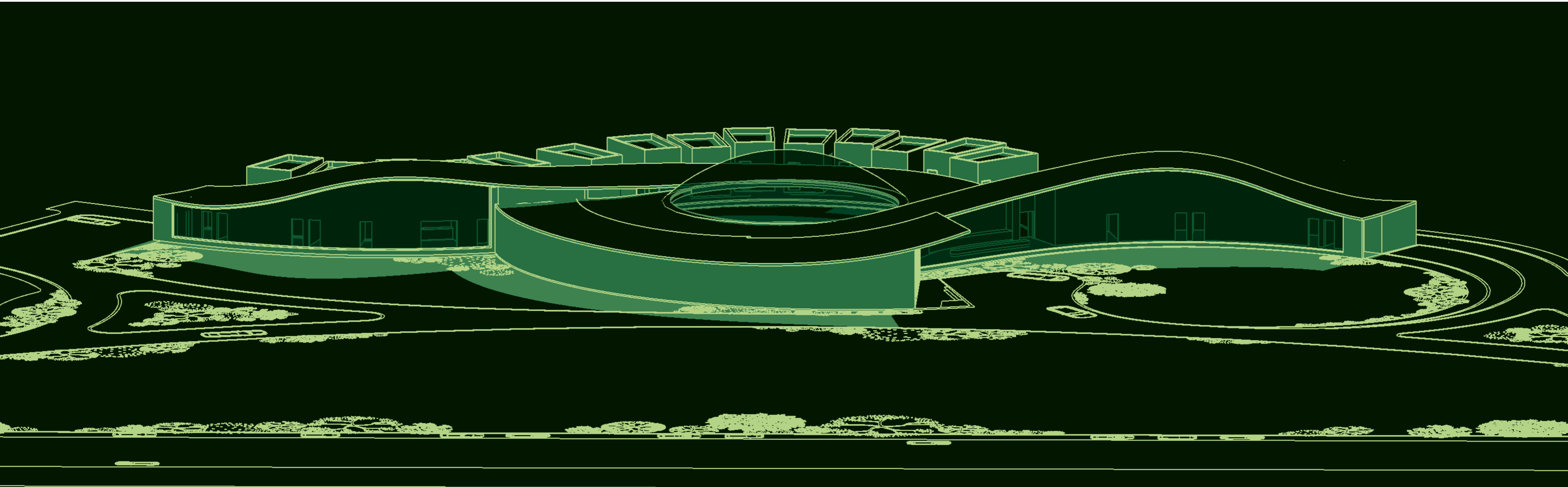

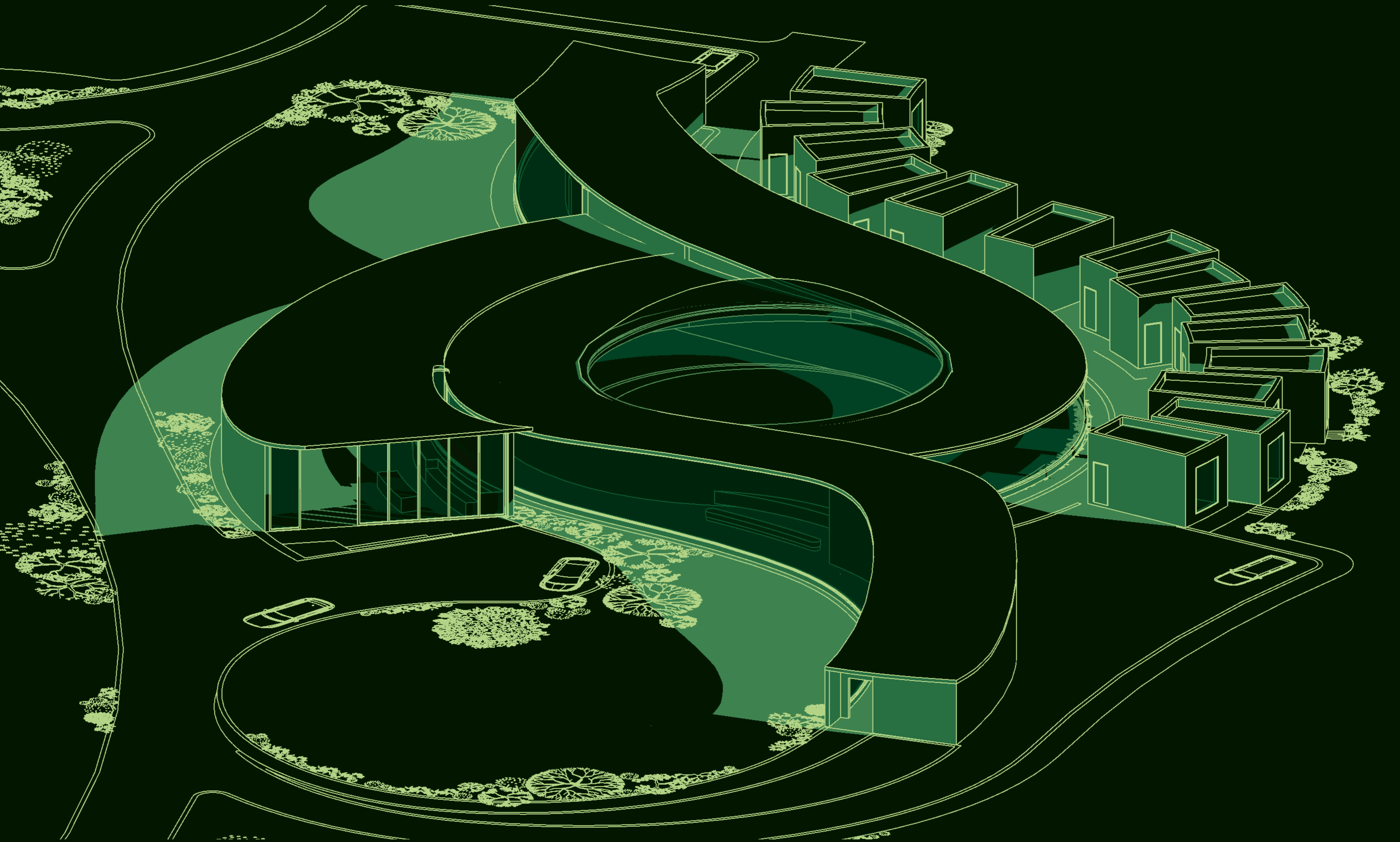

SOUTH PERSPECTIVE VIEW

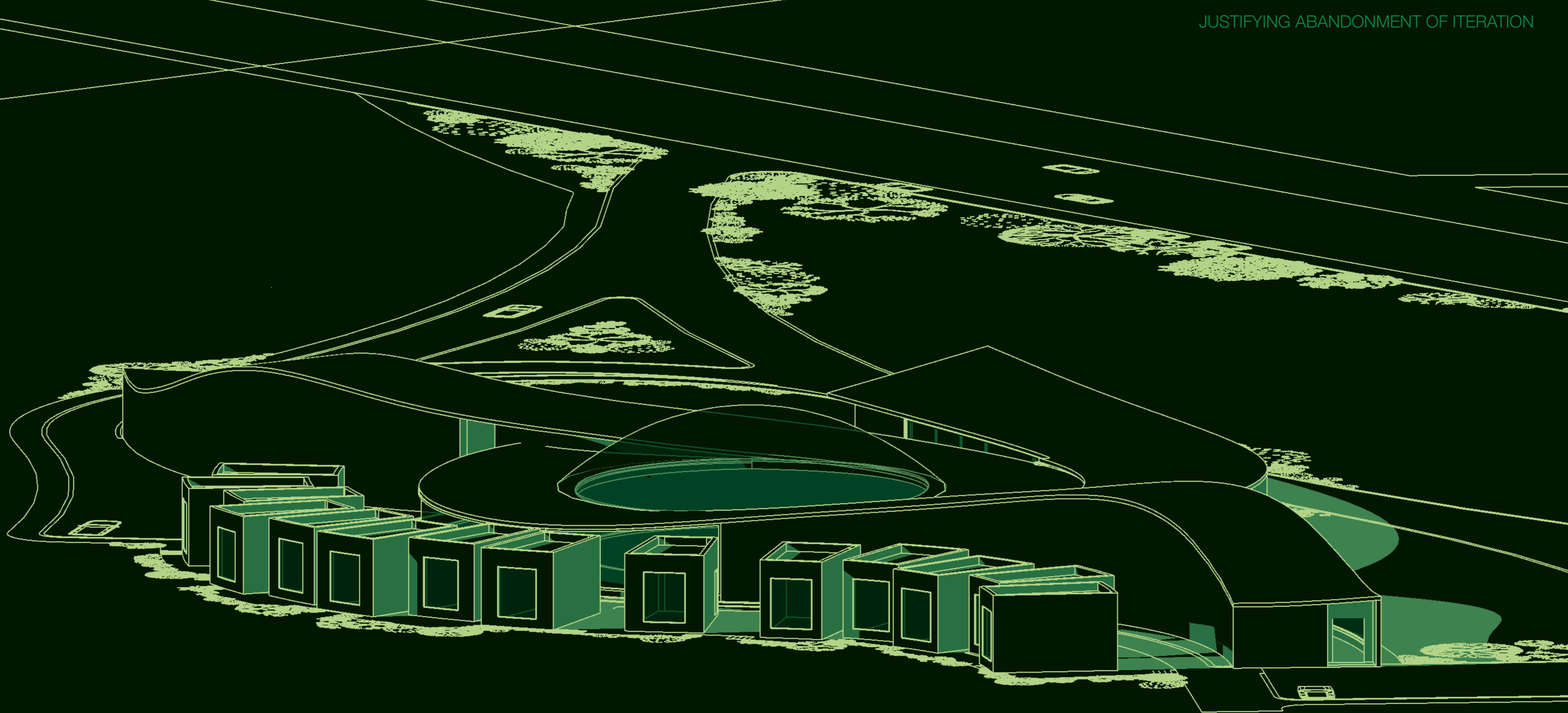

SHORTCOMINGS OF THE ITERATION

SITE CONTEXT: THE BUILDING DOES NOT RESPECT THE TOPOGRAPHY OF THE SITE AND SEEMS DISINTEGRATED FROM THE CONTEXT.

ARTIST STUDIOS: HAVING THE ARTIST STUDIOS AS INDIVIDUAL MODULES IS NOT A SUSTAINABLE SOLUTION BOTH FROM THE STRUCTURAL AND ENVIRONMENTAL PERSPECTIVES

GLASS DOME: THE GLASS DOME OF SUCH A LARGE DIAMETER MIGHT NOT BE ENVIRONMENTALLY COMFORTABLE IN TERMS OF SOLAR RADIATION, GLARE AND OVERHEATING FOR AN ART GALLERY SPACE

REITERATING

THE PREVIOUS ITERATION DID NOT RESPECT THE TOPOGRAPHY OF THE SITE. TO HAVE A MORE SITE INTEGRATED BUILDING GEOMETRY, THE CONTOUR LINES OF THE CHOSEN SITE WERE STUDIED

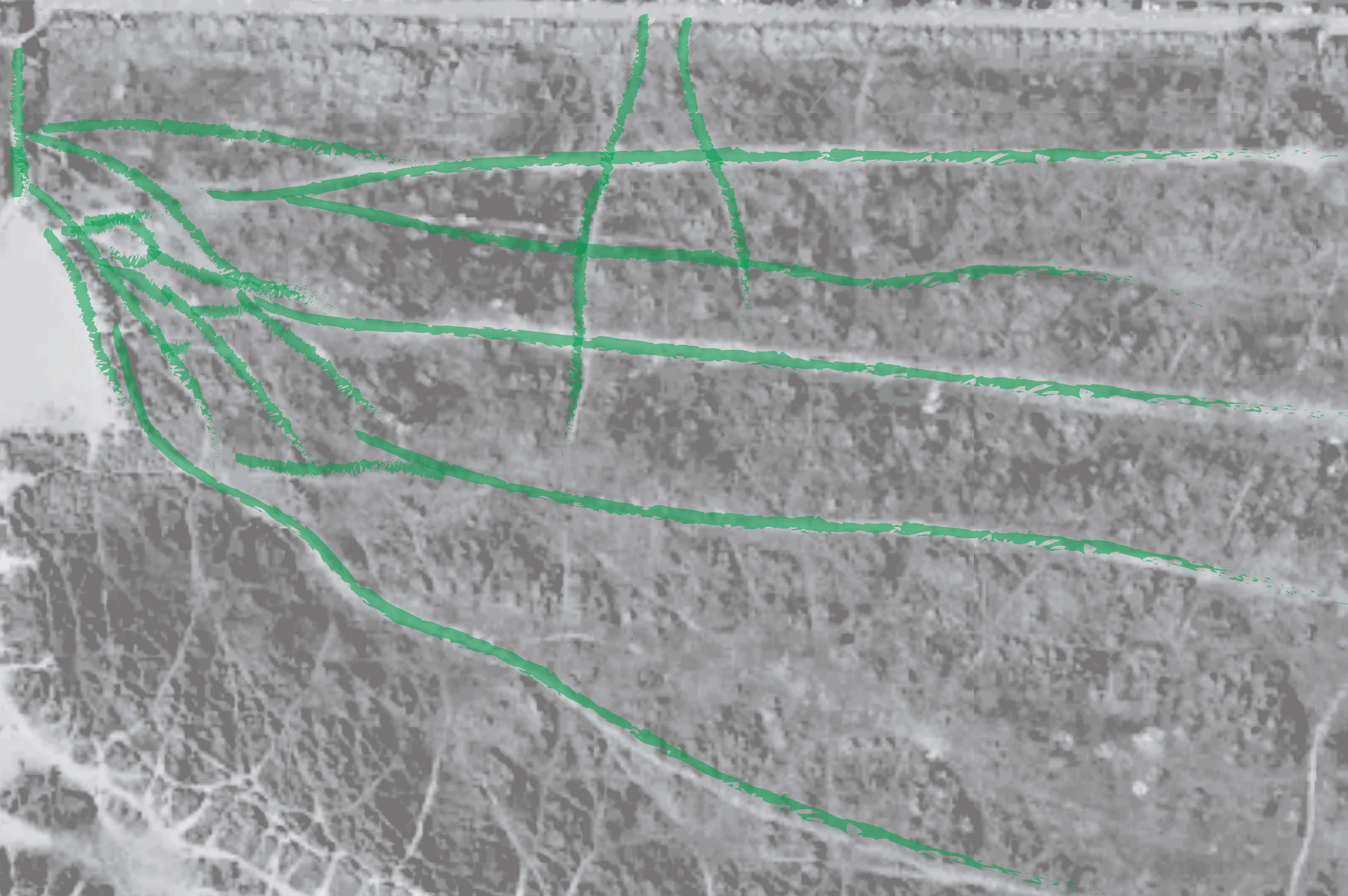

SUMMER SOLSTICE

AUTUMN EQUINOX

NORTH

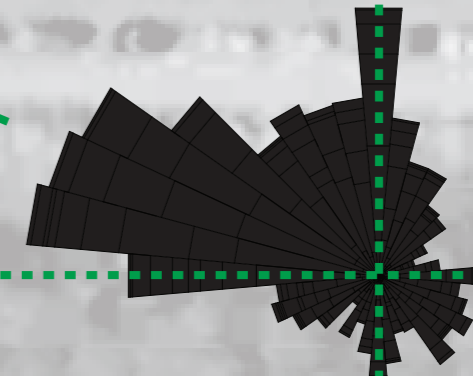
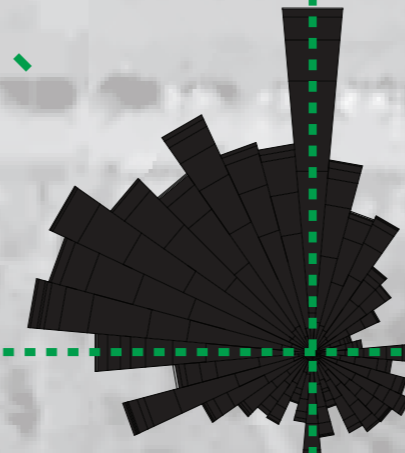

WINTER SOLSTICE

SPRING EQUINOX

NORTH

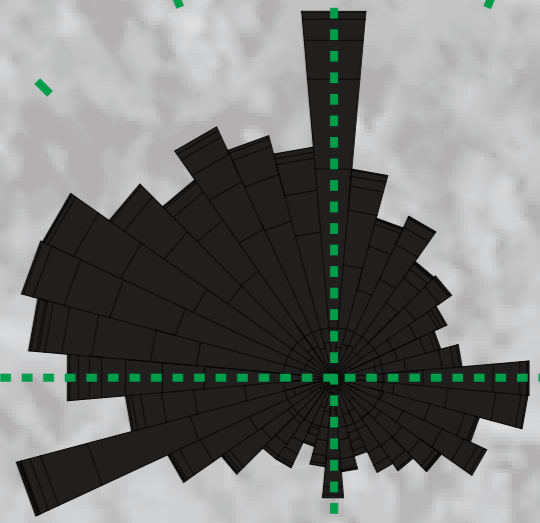
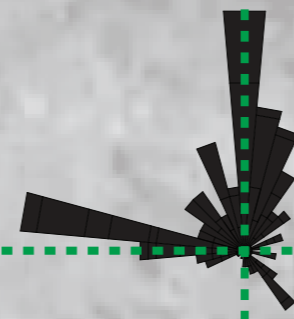

EAST

EAST

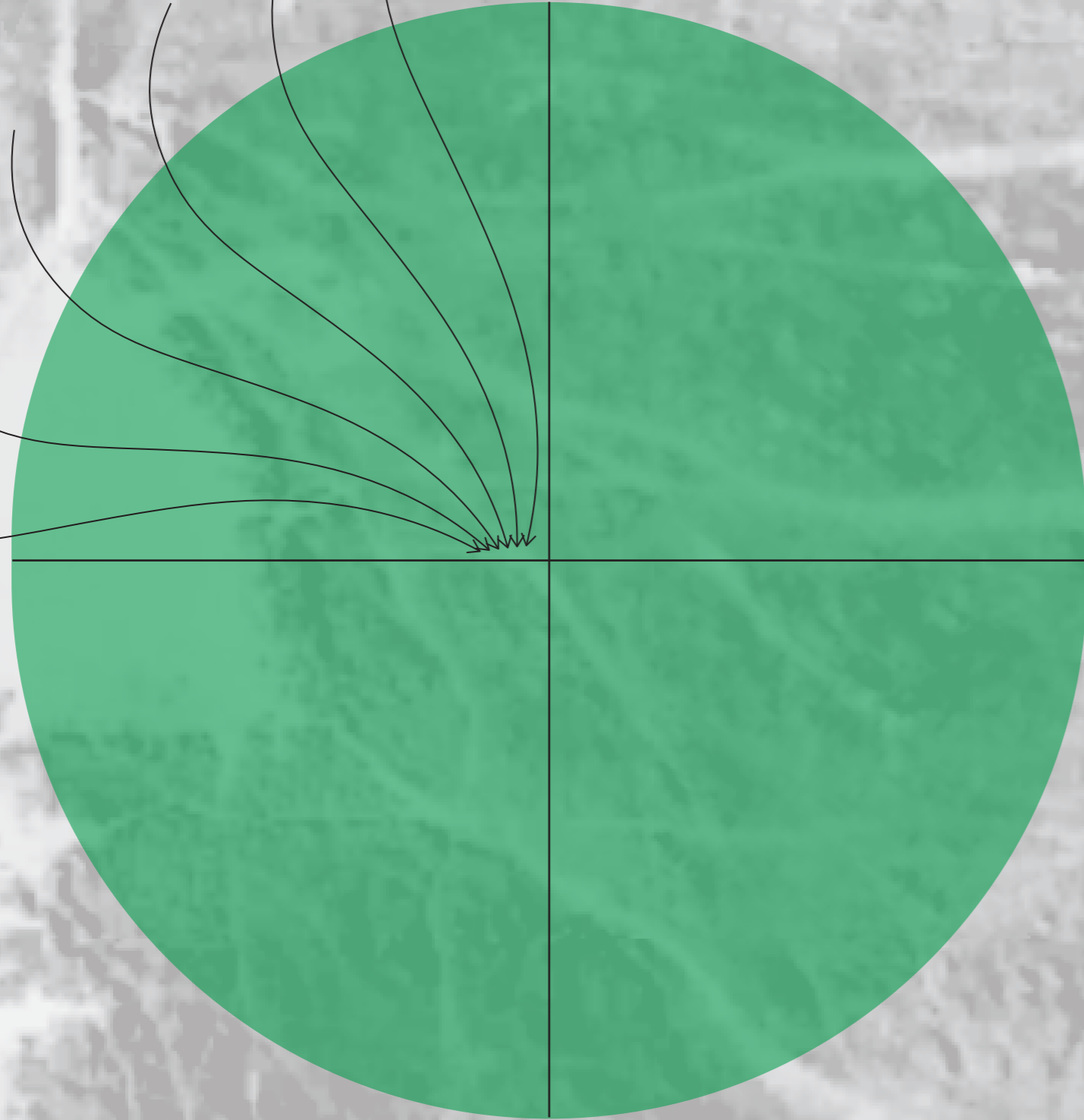

THE CREAL CENTRE PROJECT
SARA MOTWANI UNIT 8

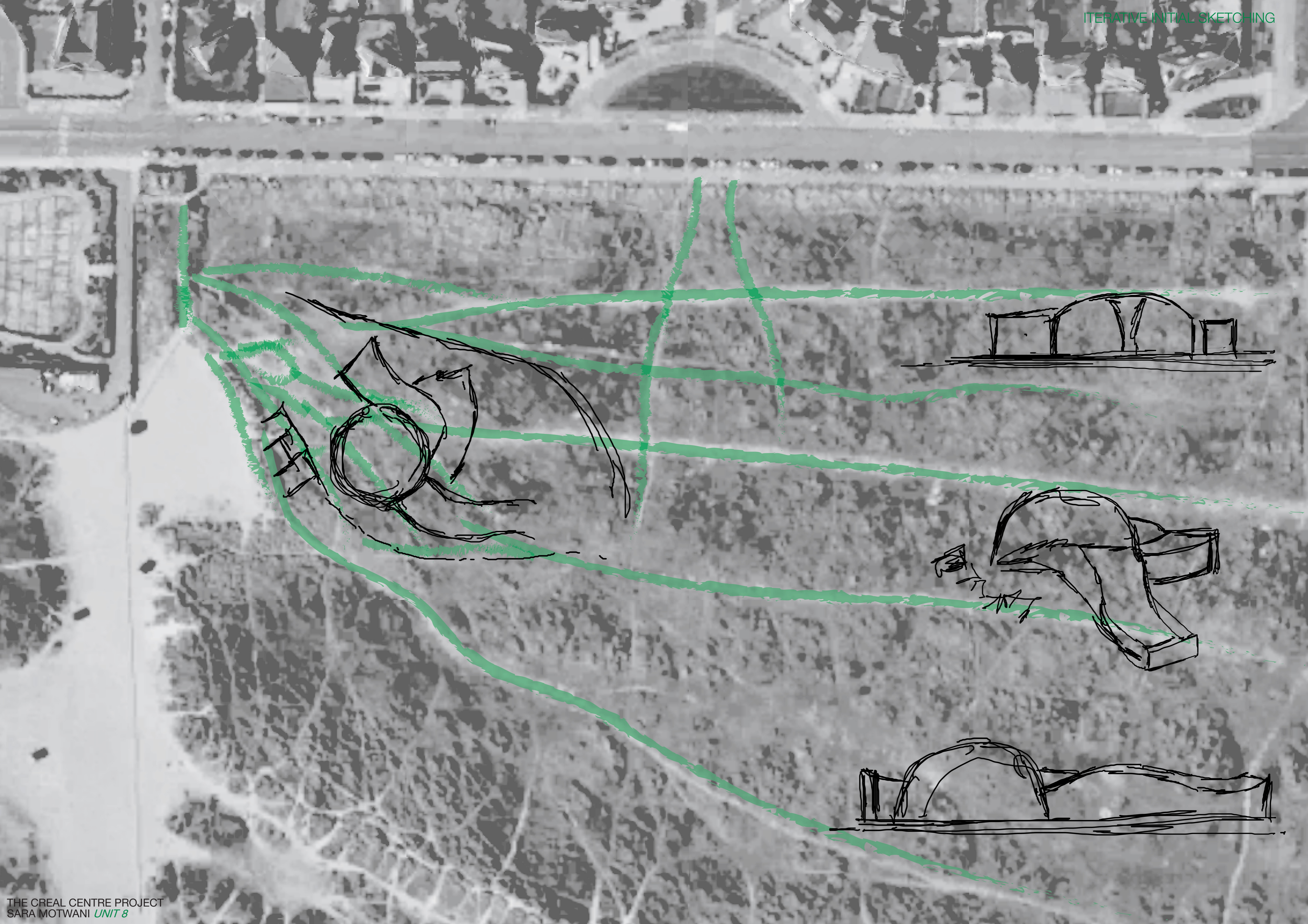



THE GRID HELPS CREATE THE DESIRED FISHNET TYPE AESTHETIC AS IN ONE OF THE AESTHETIC INSPIRATIONS FOR THE DESIGN

WINDOWS ON THE EAST FACADE FOR THE THERAPY ROOMS ARE CREATED TO PROVIDE VIEWS OF THE SEA. THIS IS INTENTIONED TO HELP THE HEALING PROCESS SINCE WINDOWS ARE CONSIDERED A PORTAL TO HEALING

THE BUILDINGS FORM IS INSPIRED FROM THE LINES OF BEAUTY. THE CURVES ARE PROJECTED BOTH IN THE X-DIRECTION AS WELL AS IN THE Y-DIRECTION. THE CURVES ALSO HELP CREATE A WAVE LIKE EFFECT WHICH IS IN SYNERGY WITH THE BUILDINGS LOCATION ON THE BEACH

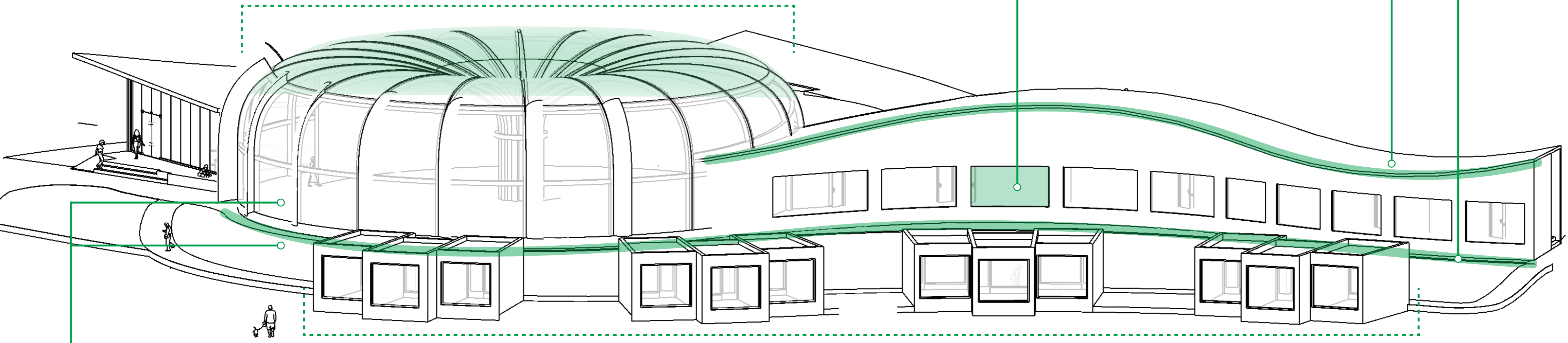

THE ARTIST STUDIOS ARE DESIGNED IN CLUSTERS AND ARRANGED IN A ROW LIKE ARRANGEMENT CLOSE TO EACH OTHER. THIS INSPIRATION FOR THE STUDIOS IS FROM THE ROWS OF GREAT YARMOUTH. THE PURPOSE IS TO EMULATE THE COMMUNITY LIVING LIKE THAT IN THE CASE OF THE ROWS. THIS COULD CREATE OPPORTUNITIES FOR COLLABORATION AND NETWORKING AND RESULT IN THE GROWTH OF THE ARTIST COMMUNITY IN GREAT YARMOUTH.

THE BUILDING IS DESIGNED IN A WAY TO CREATE AN INTERACTION BETWEEN THE INDOOR AND OUTDOOR ENVIRONMENTS.





FINAL ITERATION

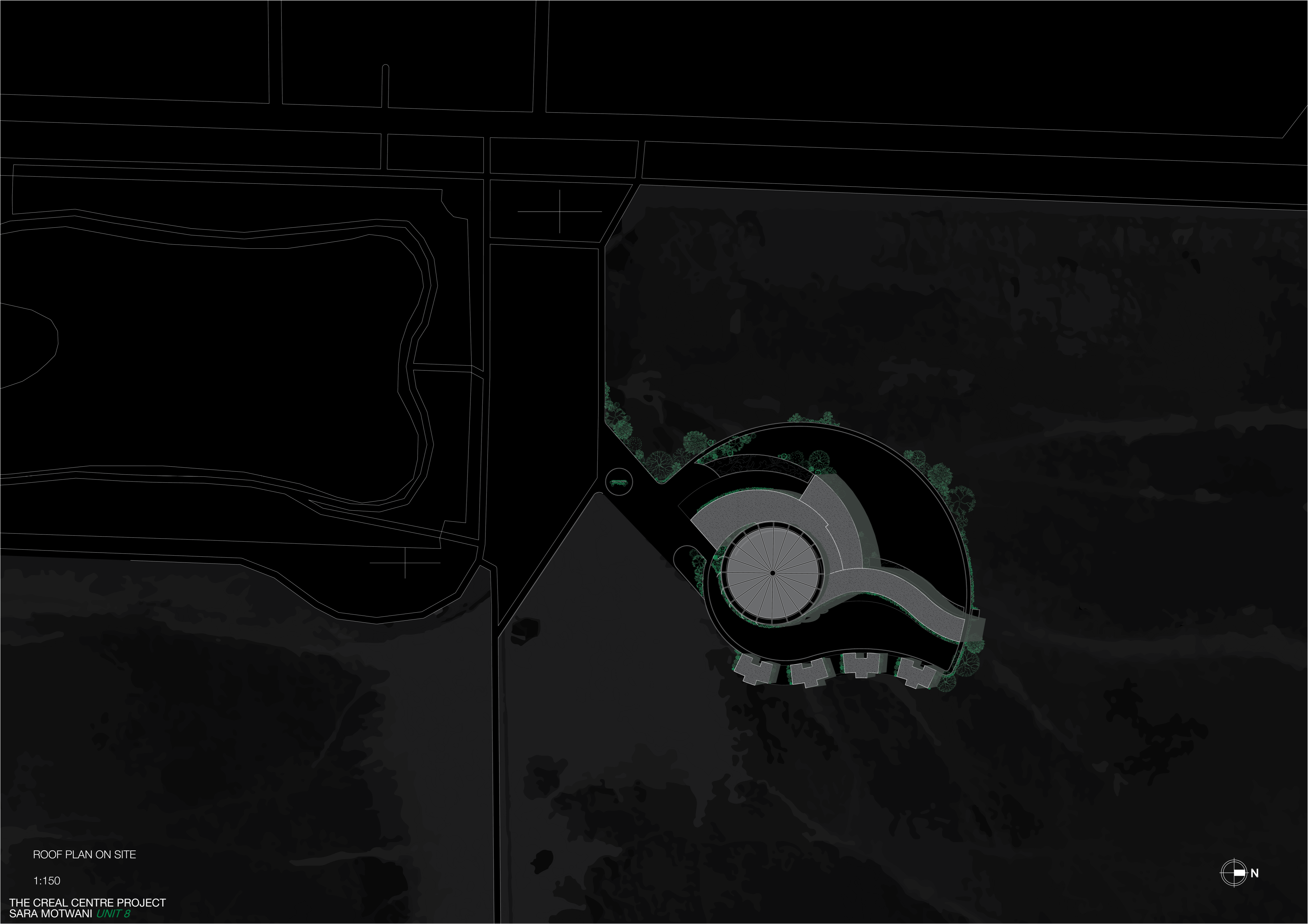

ROOF PLAN ON SITE

1:150

THE CREAL CENTRE PROJECT
SARA MOTWANI *UNIT 8*



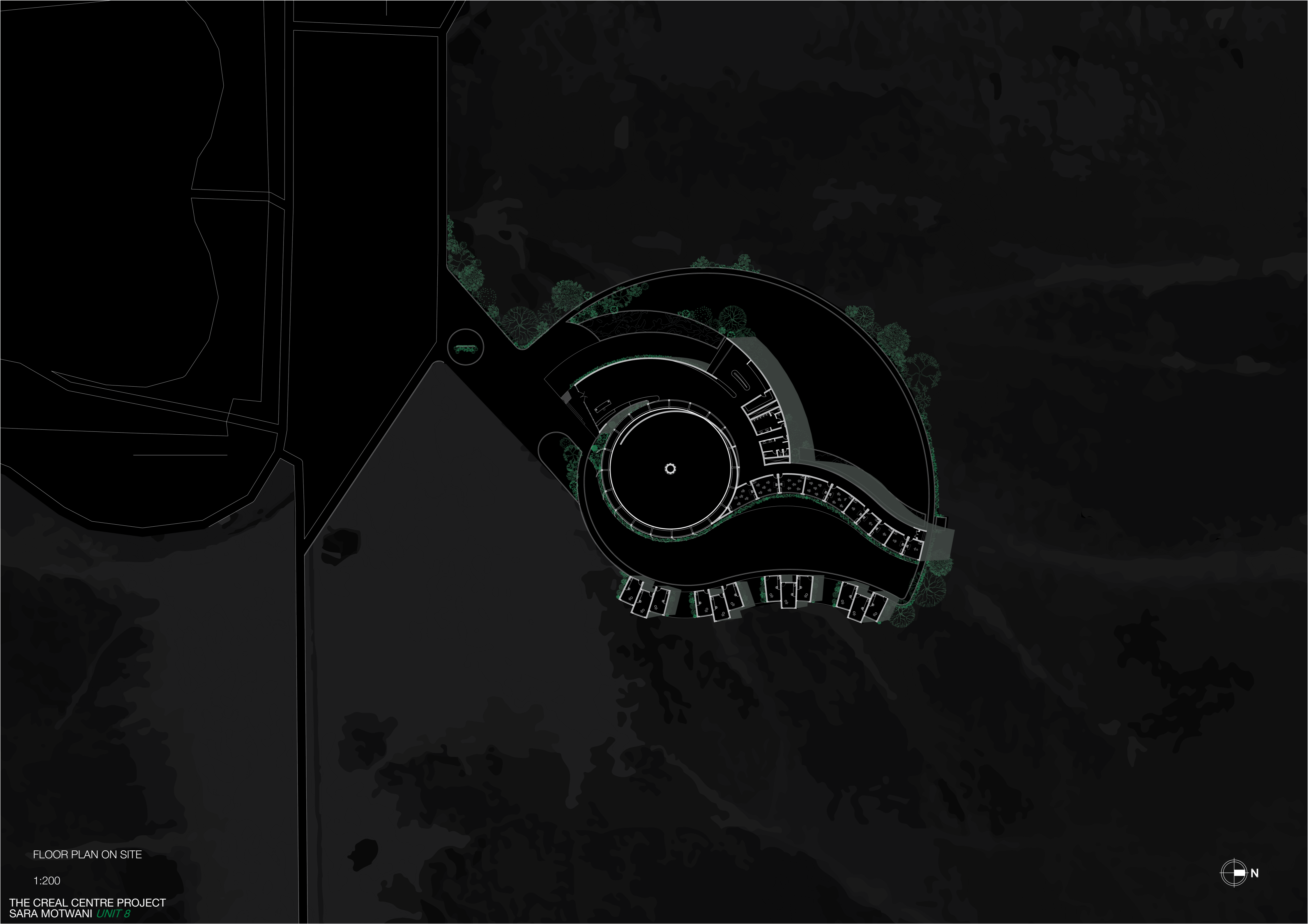

FLOOR PLAN ON SITE

1:200

THE CREAL CENTRE PROJECT
SARA MOTWANI *UNIT 8*



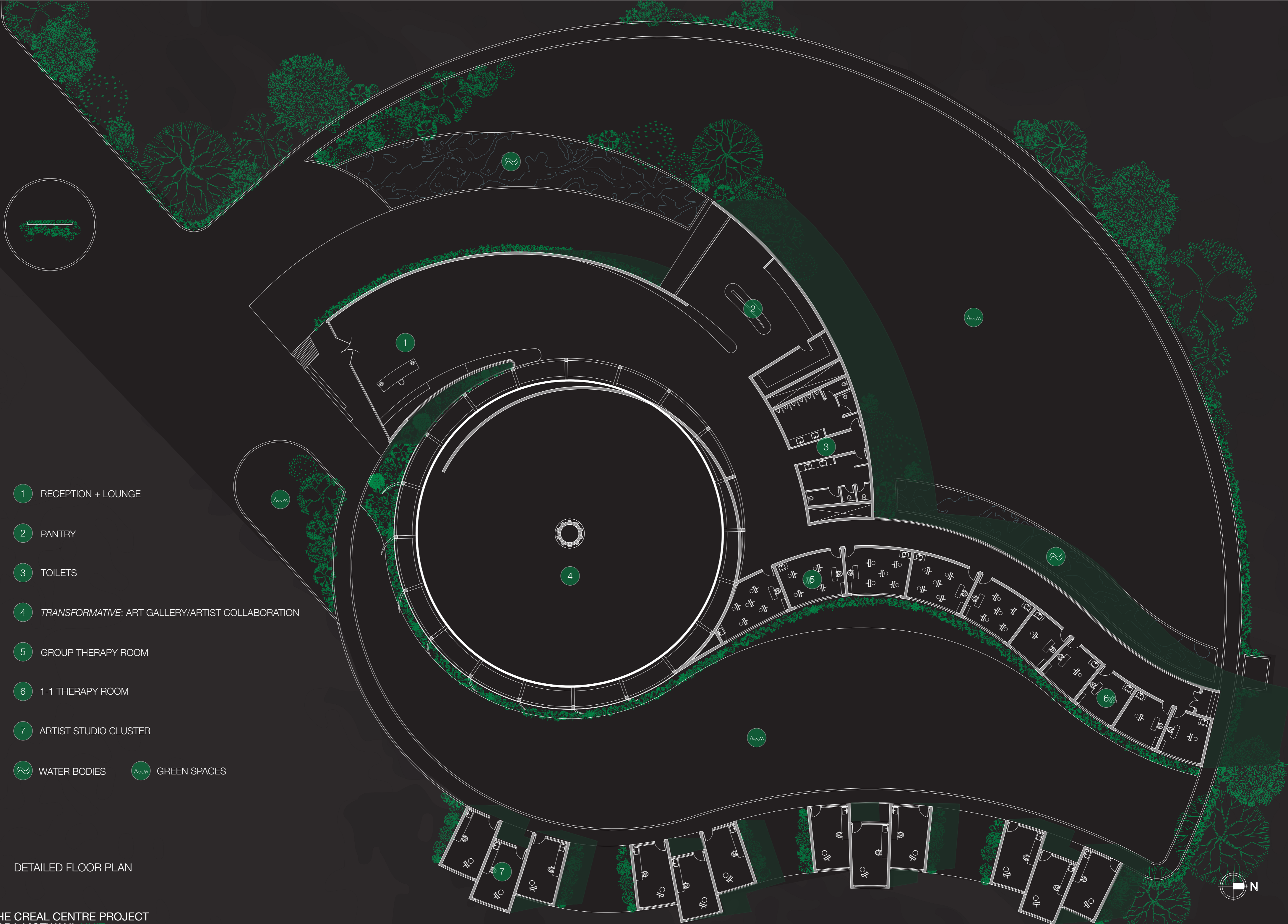

- 1 RECEPTION + LOUNGE
- 2 PANTRY
- 3 TOILETS
- 4 TRANSFORMATIVE: ART GALLERY/ARTIST COLLABORATION
- 5 GROUP THERAPY ROOM
- 6 1-1 THERAPY ROOM
- 7 ARTIST STUDIO CLUSTER
- WATER BODIES
 GREEN SPACES

DETAILED FLOOR PLAN



WEST ELEVATION

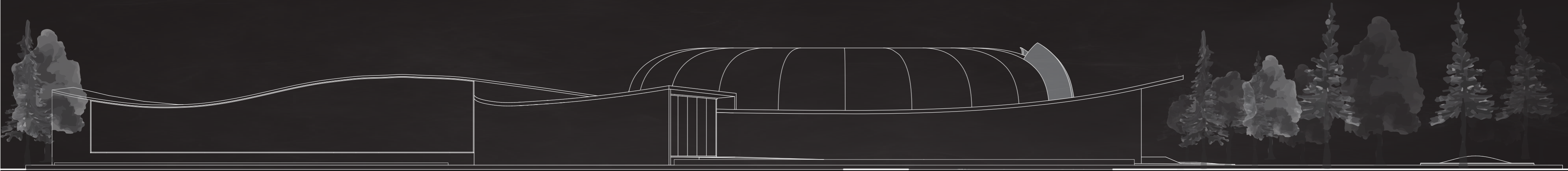

SOUTH ELEVATION

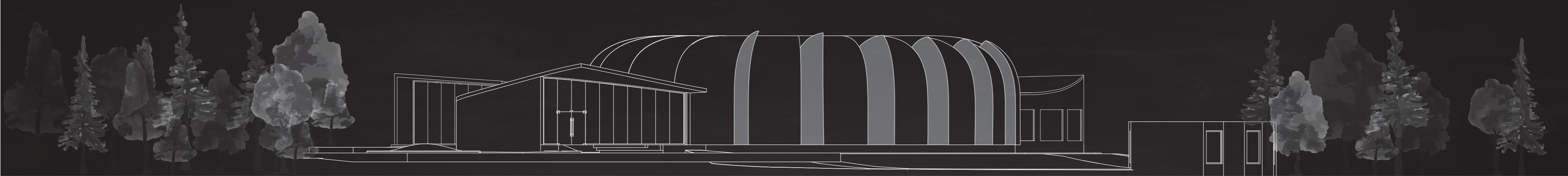

EAST ELEVATION

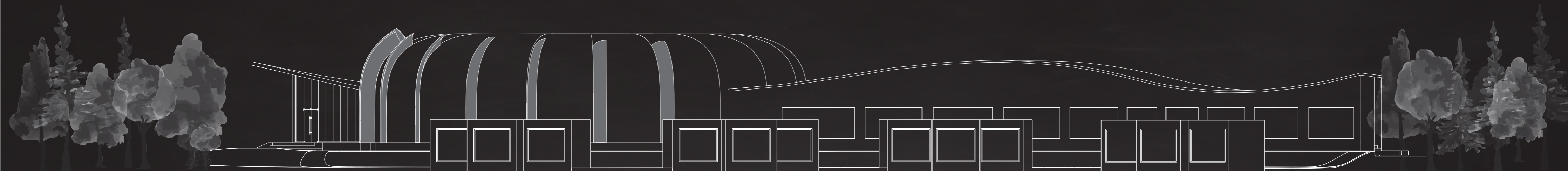

SECTION REPRESENTING STRUCTURAL CONNECTIONS

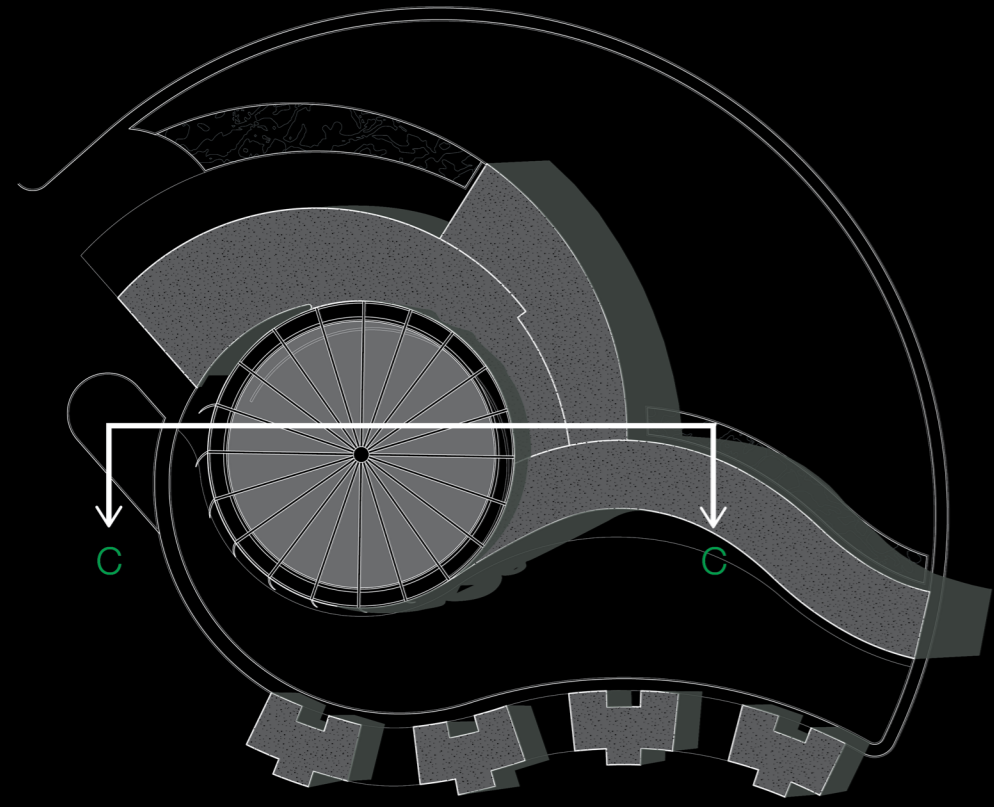

SECTION C-C
SCALED 1:200

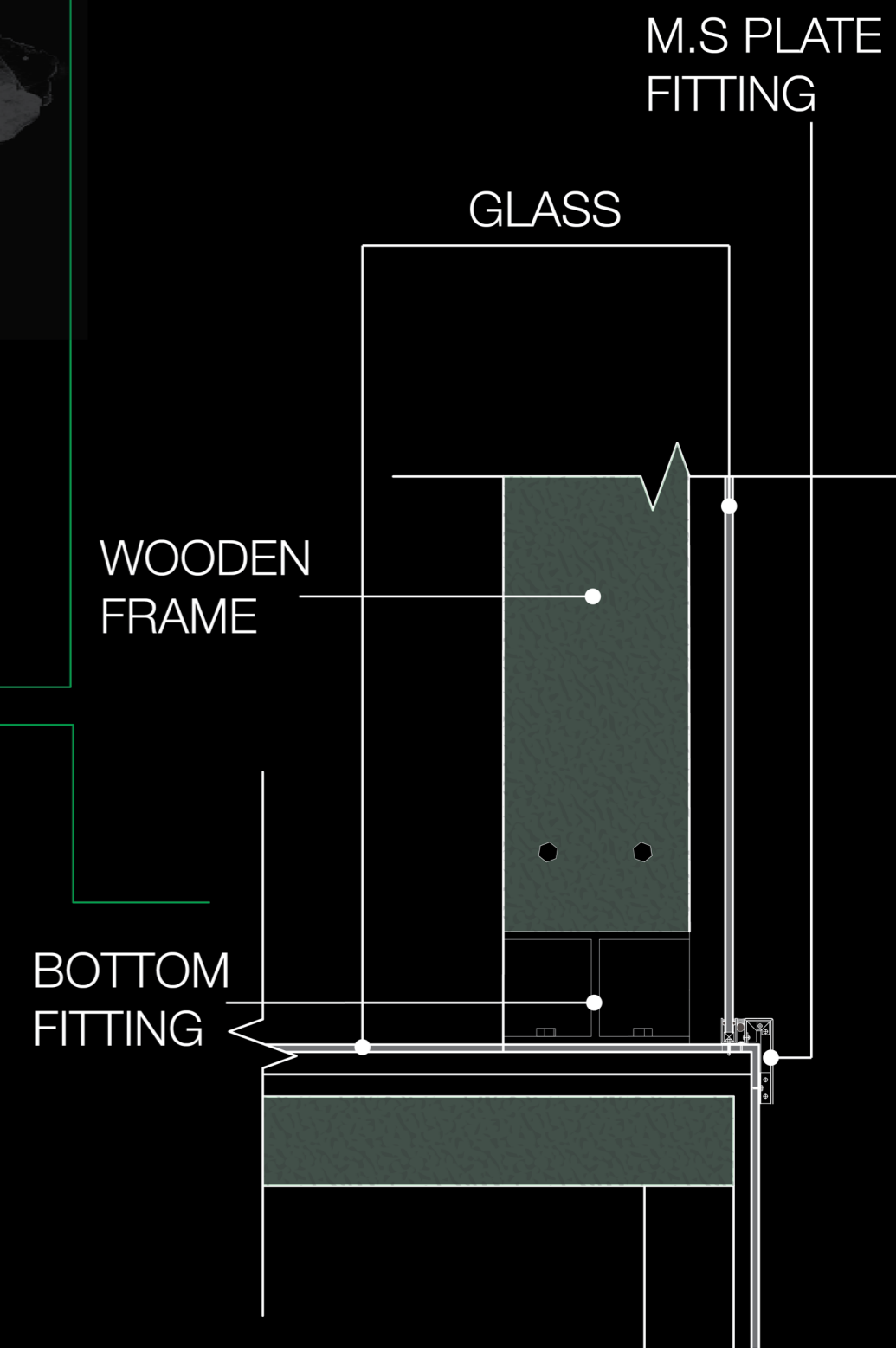
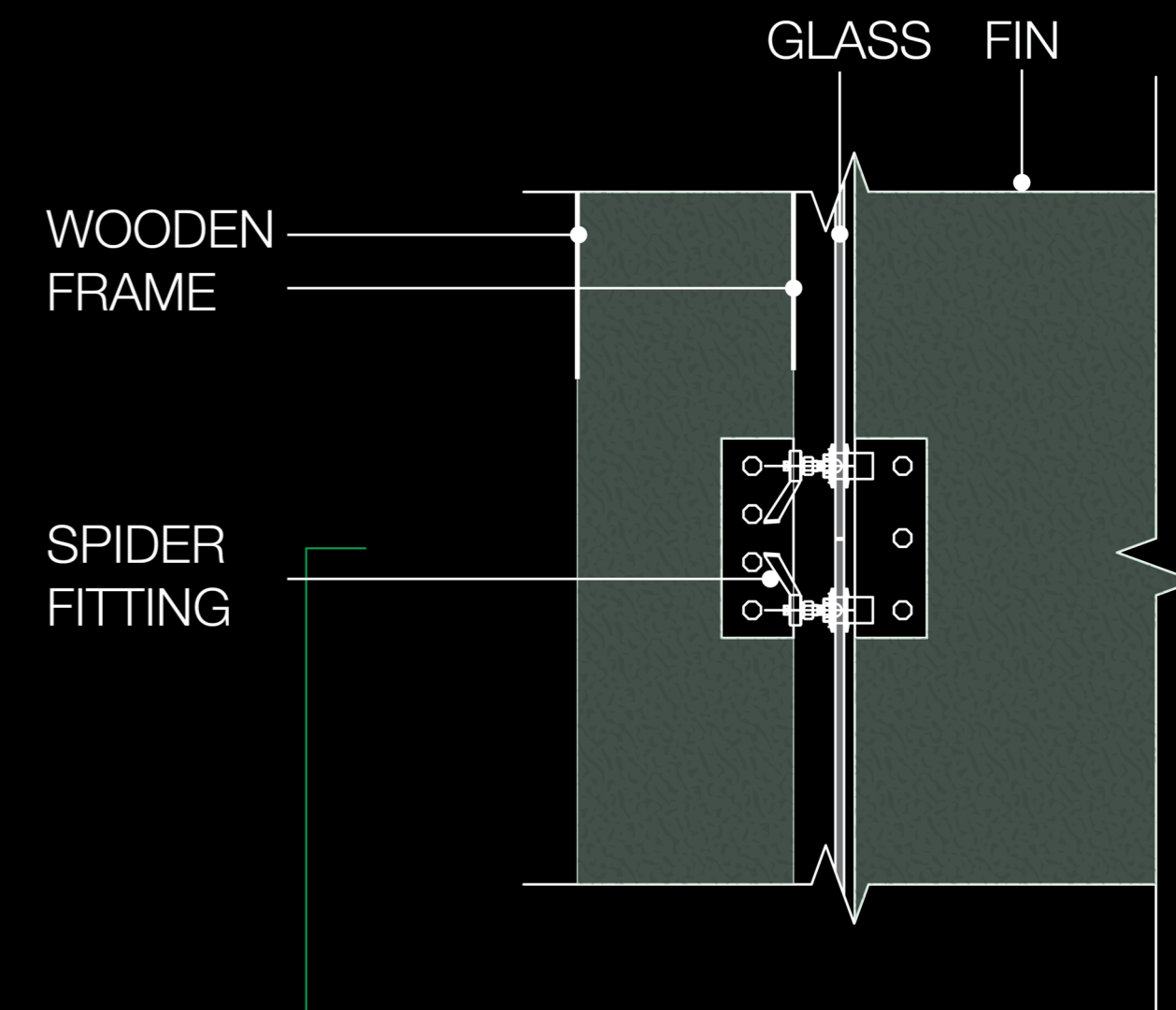
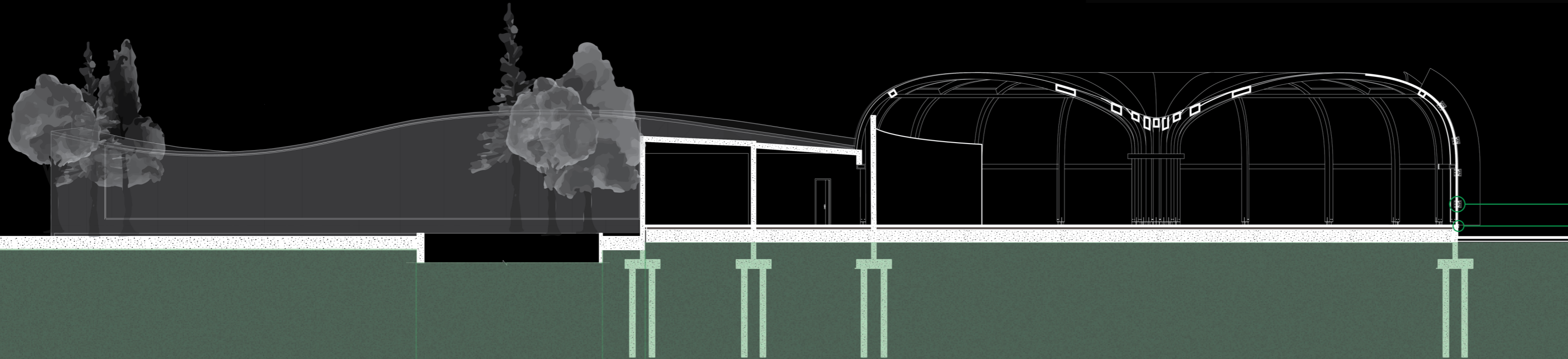
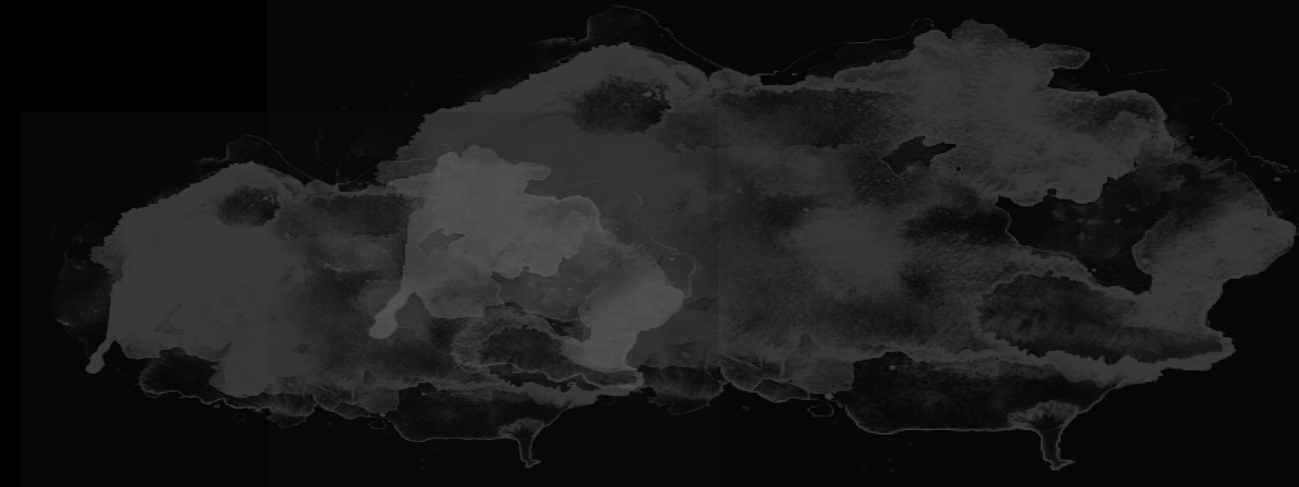
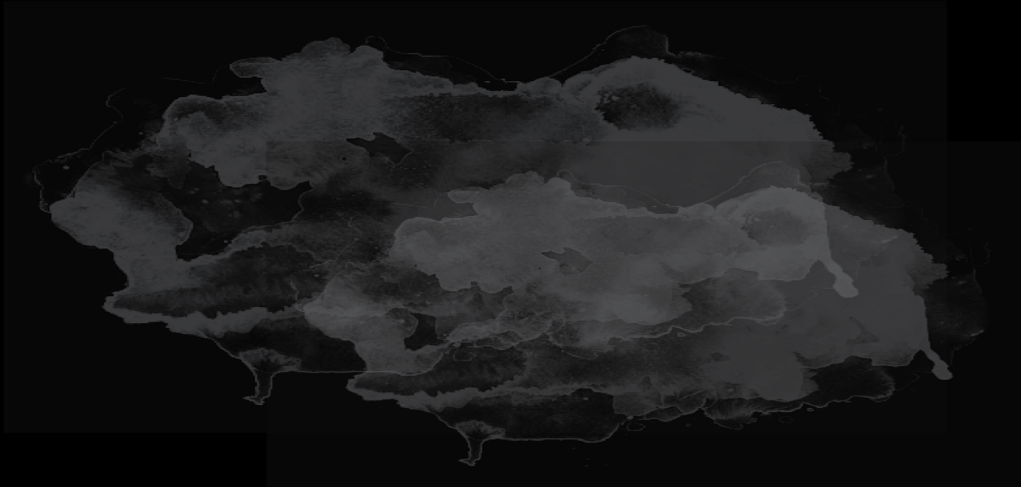

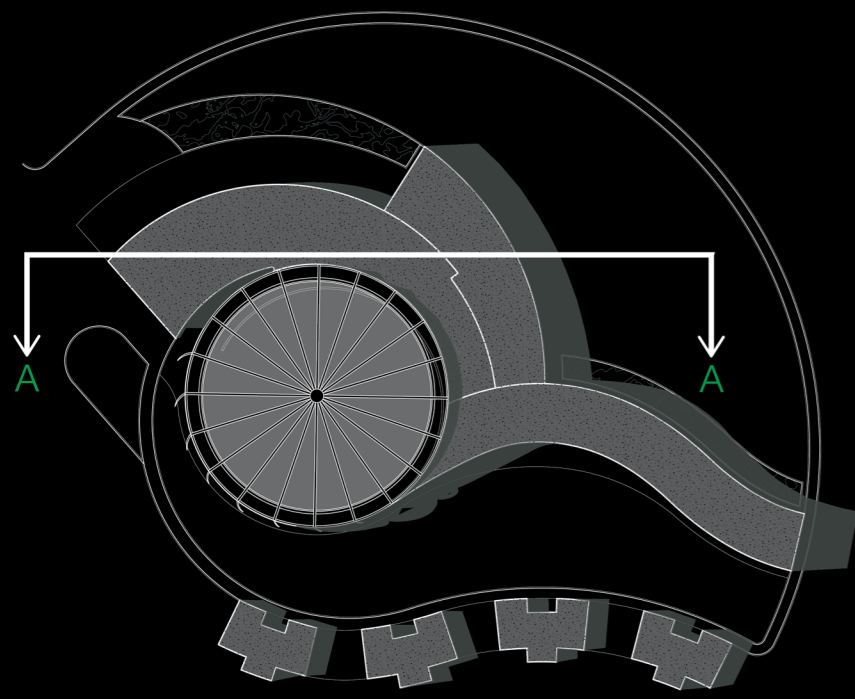

SECTION A-A
SCALED 1:200

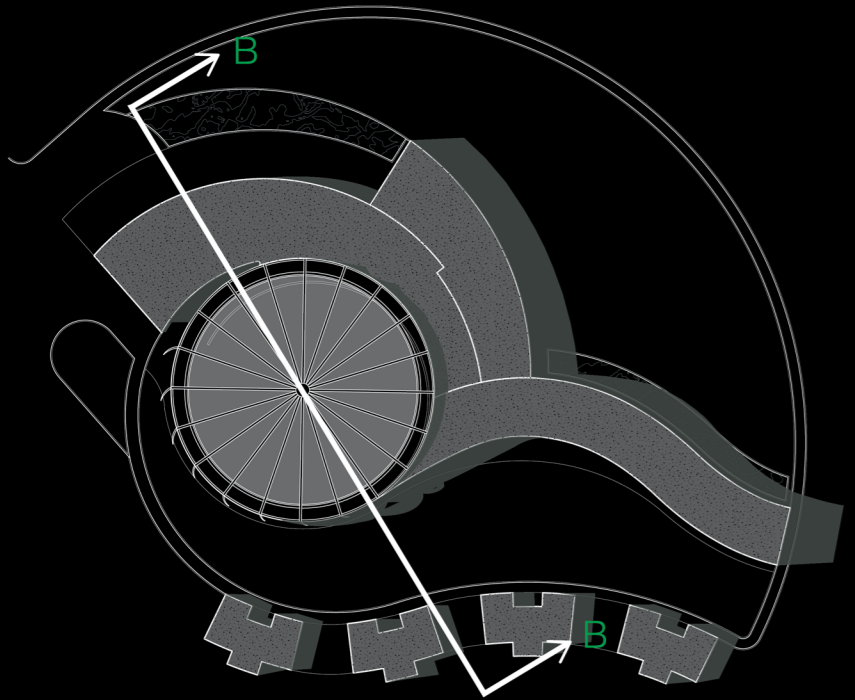
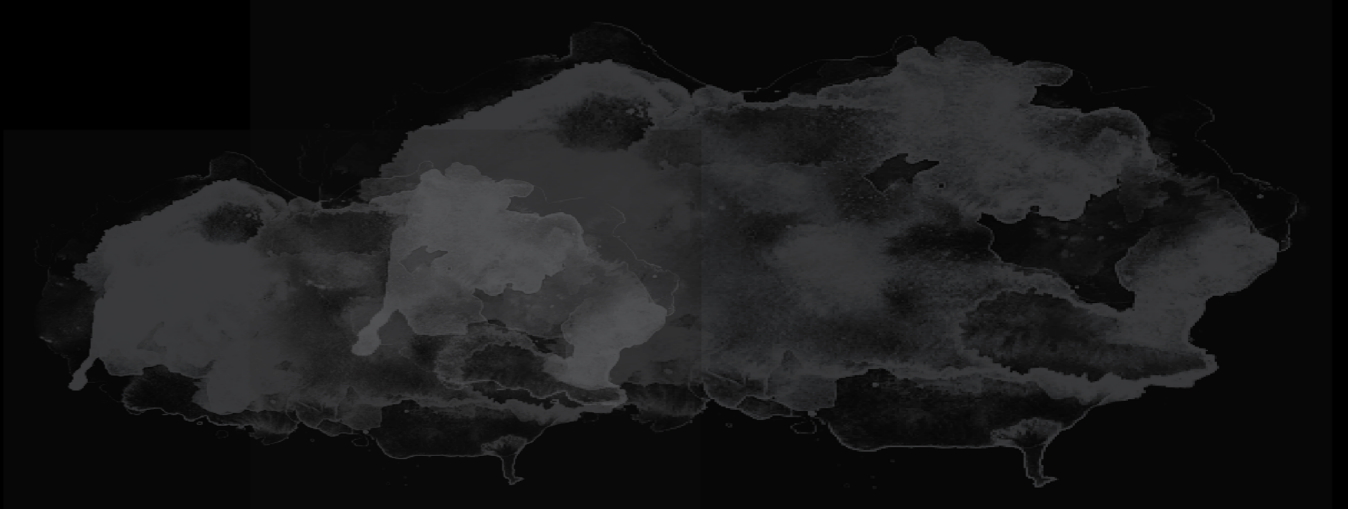
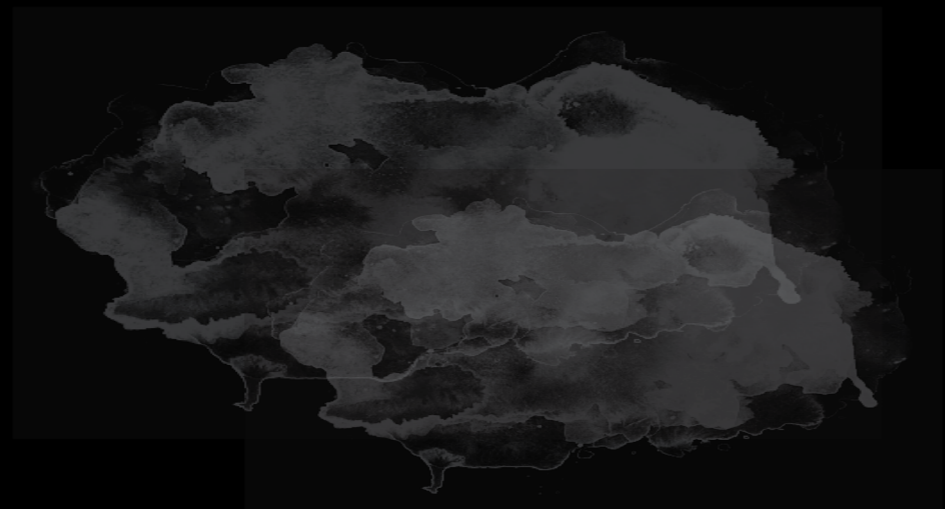
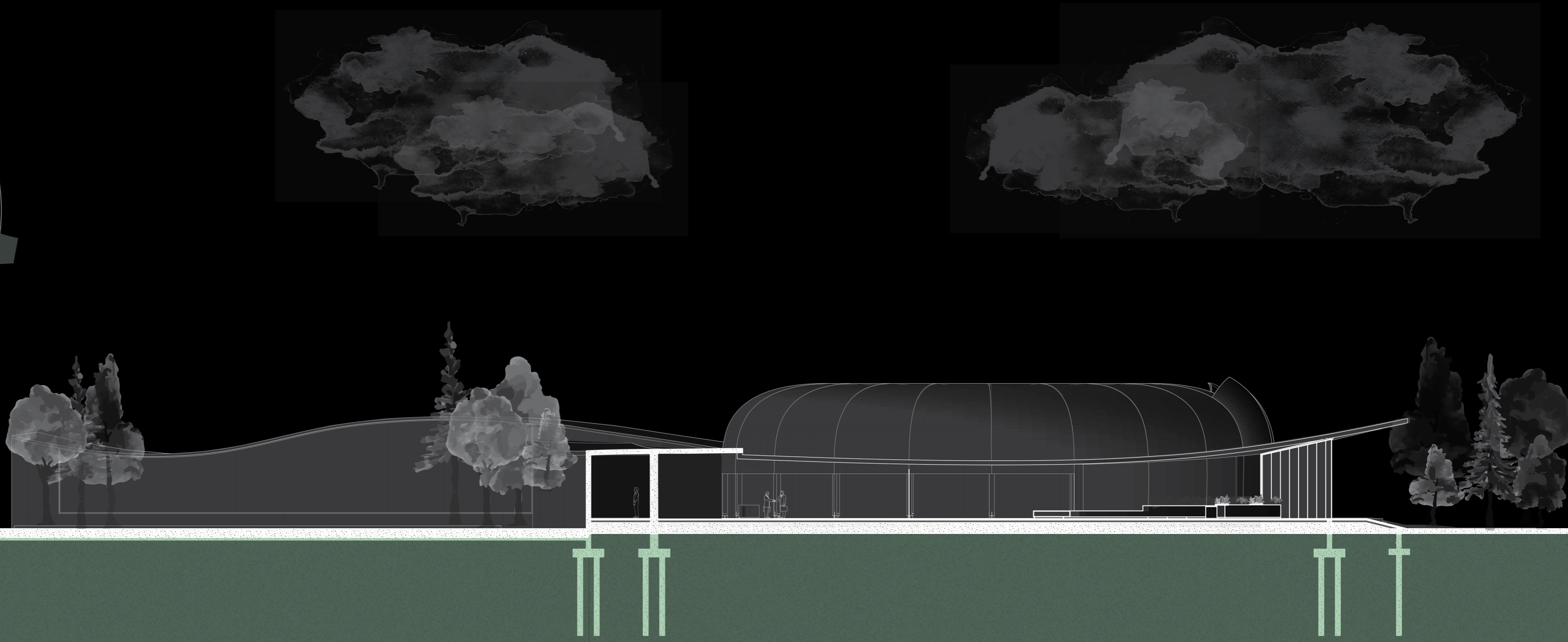

SECTION B-B
SCALED 1:200

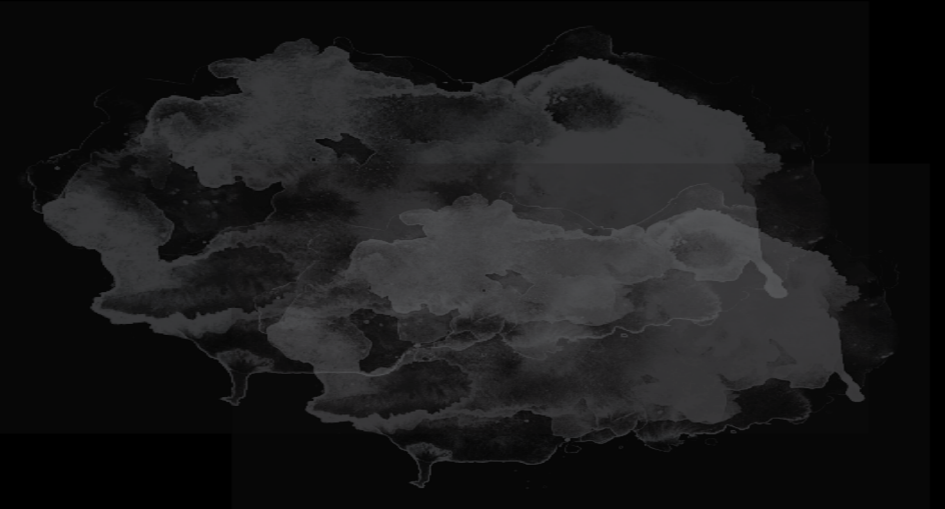
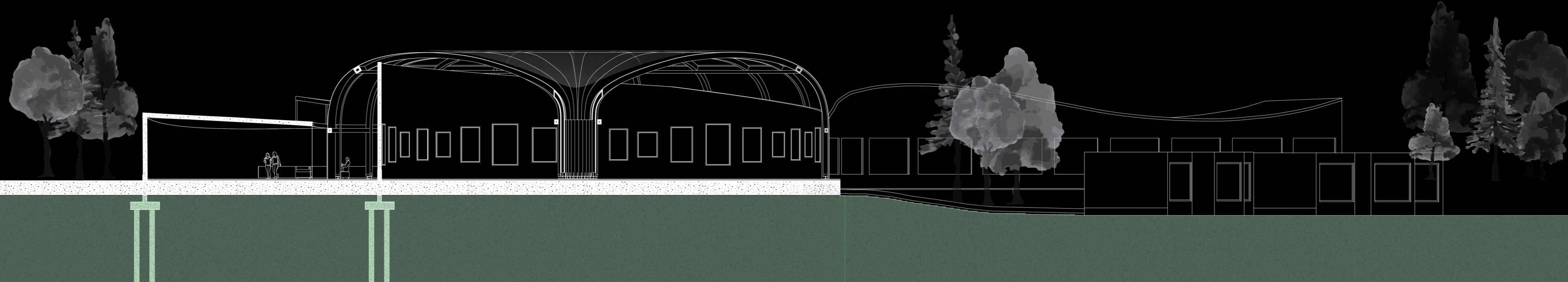



MATERIAL CONSIDERATIONS



FISHNET RE-INFORCED CONCRETE

STRUCTURAL
COMPOSITION OF
FISHNET REINFORCED
CONCRETE:

Concrete Mix Design: The concrete mix used in fishnet reinforced concrete is similar to conventional concrete. It consists of cement, aggregates (such as sand and gravel), and water. The fishnets are added as an additional component during the mixing process.

Mixing Process: During the concrete mixing process, the fishnets are added and dispersed evenly within the mixture. The fishnets intertwine, creating a three-dimensional reinforcement system within the concrete.

Casting and Curing: The fishnet reinforced concrete is then cast into desired molds or formwork. After casting, the concrete is allowed to cure, providing sufficient time for the concrete to gain strength and durability.



TIMBER

Sourcing: Timber can be locally sourced from sustainable managed forests in Norfolk and surrounding areas.

Environmental Impact: Timber has a relatively low embodied carbon compared to other construction materials. It is renewable and can store carbon over its lifecycle, making it an environmentally friendly choice. Look for sustainably certified timber, such as FSC (Forest Stewardship Council) or PEFC (Programme for the Endorsement of Forest Certification) certified wood.



PROCUREMENT

Fishnets used for reinforcing concrete can be sourced from fishing industries or fishnet manufacturers. These fishnets can be collected as waste material after their useful life or as byproducts from fishing activities, maintaining structural integrity.

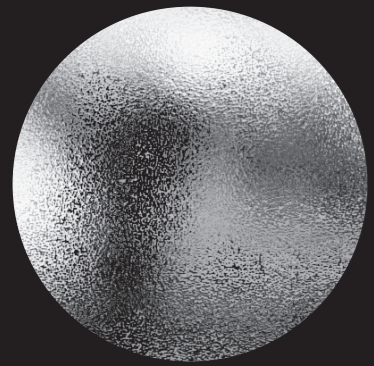

GLAZING

GLAZING (PARTICULARLY TRIPLE GLAZING) ALONG WITH STEEL ARE USED AS SECONDARY MATERIALS IN THE BUILDING SYSTEM.

FOR MAXIMISING VIEWS AND DAYLIGHTING LARGE AMOUNTS OF GLAZING ARE REQUIRED ON THE BUILDING FACADE.

STEEL IS USED PRIMARILY AS A MATERIAL OF STRUCTURAL IMPORTANCE AND USED IN JOINTS AND STRUCTURAL CONNECTIONS.



STEEL

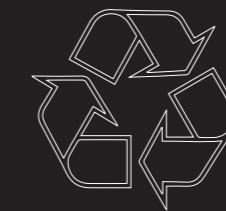

Utilizing waste materials: By repurposing discarded fishnets, this approach helps reduce environmental waste and promotes recycling efforts.

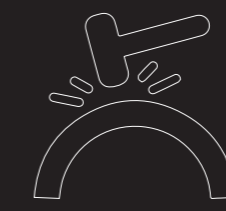

Strength and Durability: The fishnets provide additional tensile strength to the concrete, enhancing its overall structural performance.

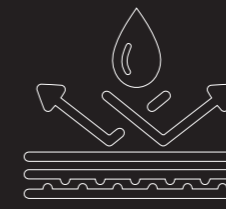

Corrosion Resistance: The synthetic materials used in fishnets, such as nylon or polyethylene, are typically resistant to corrosion, which can be advantageous in coastal environments like Great Yarmouth.



Potential Cost Savings: Incorporating recycled fishnets into concrete can potentially reduce material costs while maintaining structural integrity.

An architectural rendering of a modern building complex. The main building is a long, low-profile structure with a curved roofline and a series of windows. In the foreground, there are several smaller, rectangular structures with windows, possibly kiosks or service units. The background features a desert landscape with several palm trees and a clear sky. The overall scene is presented in a light, semi-transparent style.

ENVIRONMENTAL CONSIDERATIONS

1ST ITERATION

WINDOW SHADING: TRANSPARENT INSULATION
LOCAL SHADING: OVERHANG + SIDEFINS (0.5 m)
GLAZING TYPE: DOUBLE GLAZING, 30% GLAZED

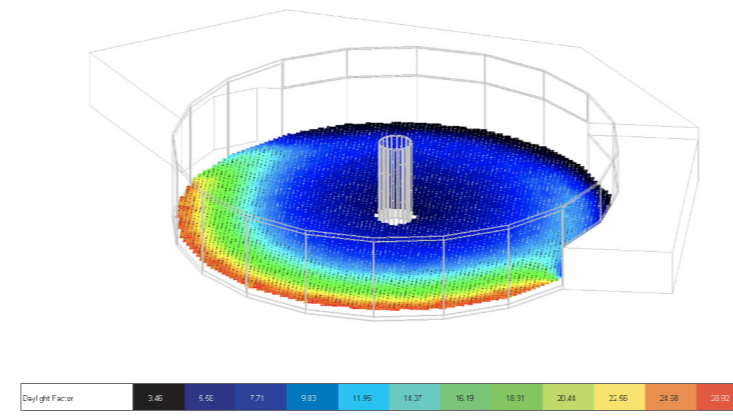
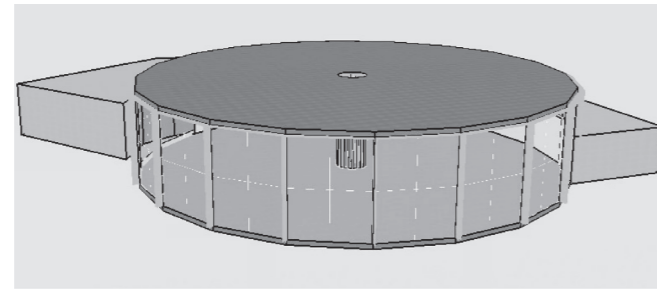

AVERAGE DAYLIGHT FACTOR = 11.930%

2ND ITERATION

WINDOW SHADING: TRANSPARENT INSULATION
LOCAL SHADING: OVERHANG + SIDEFINS (0.5 m)
GLAZING TYPE: TRIPLE GLAZING, 30% GLAZED
GLAZING SPECIFICATION: TRP CLR 3mm/13mm AIR

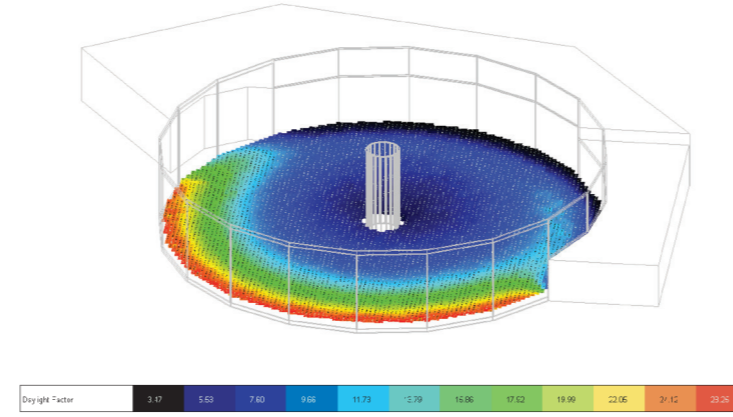
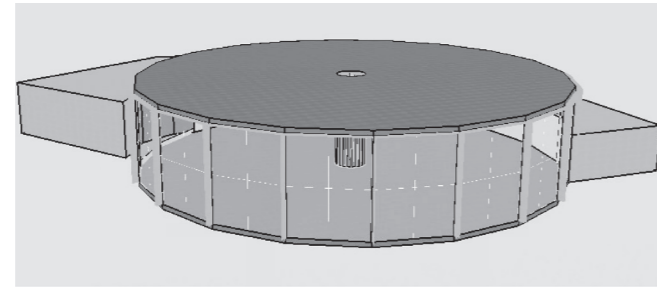

AVERAGE DAYLIGHT FACTOR = 11.845%

3RD ITERATION

WINDOW SHADING: TRANSPARENT INSULATION
LOCAL SHADING: OVERHANG + SIDEFINS (1 m)
GLAZING TYPE: TRIPLE GLAZING, 30% GLAZED
GLAZING SPECIFICATION: TRP CLR 3mm/13mm AIR

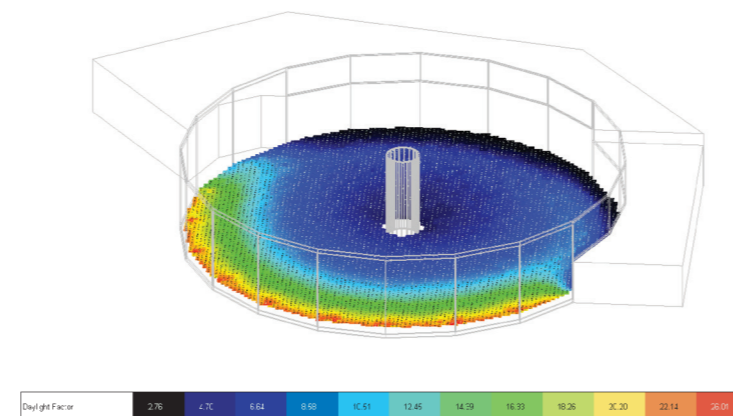
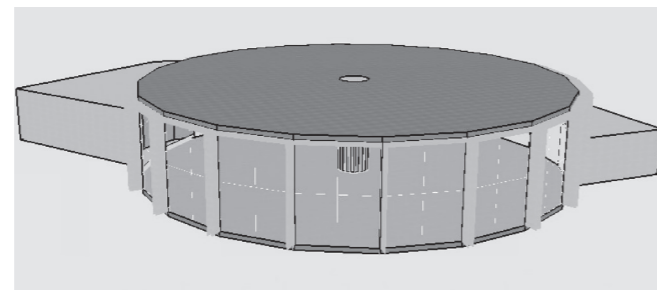

AVERAGE DAYLIGHT FACTOR = 9.830%

4TH ITERATION

WINDOW SHADING: TRANSPARENT INSULATION
LOCAL SHADING: OVERHANG + SIDEFINS (1.5 m)
GLAZING TYPE: TRIPLE GLAZING, 30% GLAZED
GLAZING SPECIFICATION: TRP CLR 3mm/13mm AIR

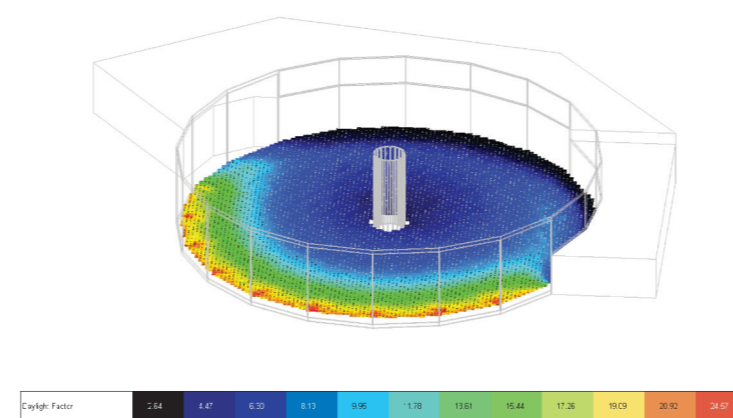
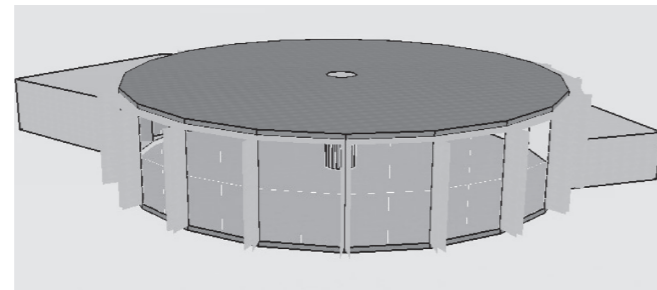

AVERAGE DAYLIGHT FACTOR = 9.213%

5TH ITERATION

WINDOW SHADING: TRANSPARENT INSULATION
LOCAL SHADING: OVERHANG + SIDEFINS (2 m)
GLAZING TYPE: TRIPLE GLAZING, 30% GLAZED
GLAZING SPECIFICATION: TRP CLR 3mm/13mm AIR

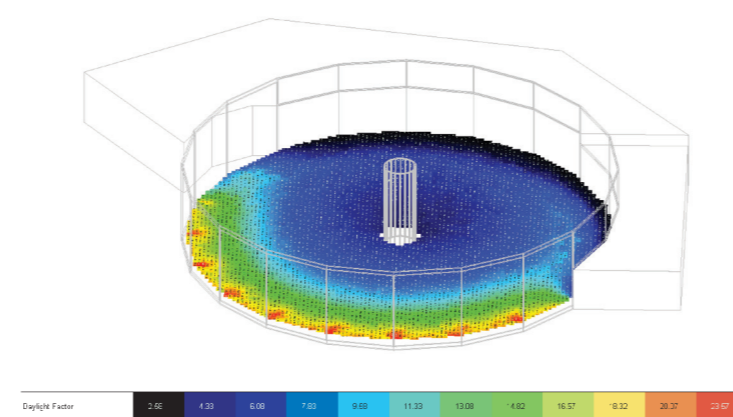
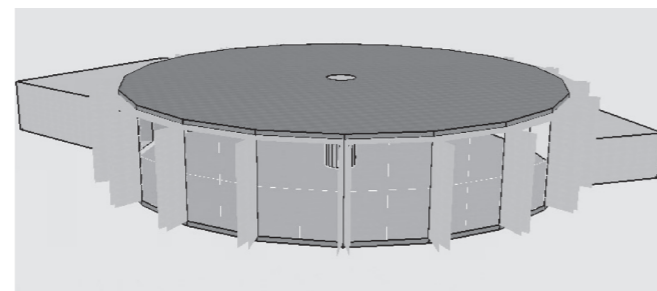

AVERAGE DAYLIGHT FACTOR = 8.940%

6TH ITERATION

WINDOW SHADING: TRANSPARENT INSULATION
LOCAL SHADING: OVERHANG (1m) + SINGLE SIDEFINS (2 m)
GLAZING TYPE: TRIPLE GLAZING, 90% GLAZED
GLAZING SPECIFICATION: TRP CLR 3mm/13mm AIR

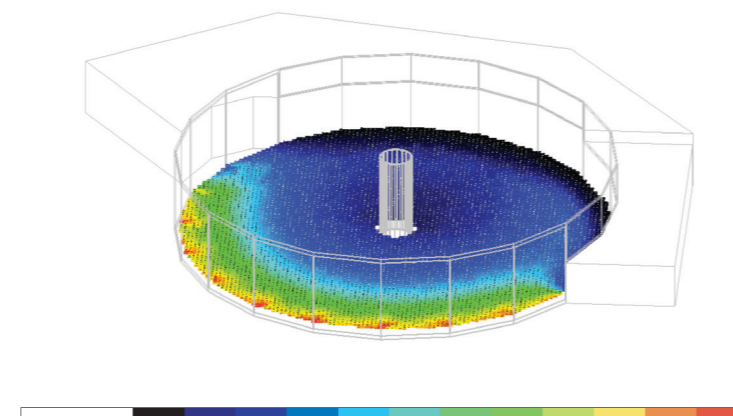
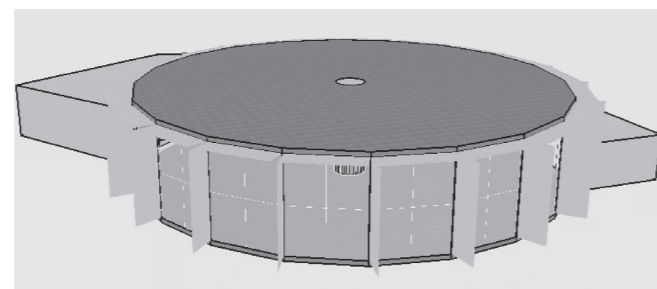

AVERAGE DAYLIGHT FACTOR = 8.373%

ANALYSIS OF THE DAYLIGHT FACTOR OF THE GALLERY SPACE WAS CONDUCTED

THE IDEAL VALUE OF THE AVERAGE DAYLIGHT FACTOR, ACCORDING TO BS 8206-2 'Code of practice for Daylighting', MUST LIE BETWEEN 2%-5%.

SINCE THE SPACE IS HEAVILY GLAZED, INITIAL VALUES PRESENTED WERE VERY HIGH. IN ORDER TO LOWER THE VALUES VARIOUS DIFFERENT STRATEGIES WERE ITERATED.

THE PROCESS INVOLVED VARYING THE GLAZING TYPE AND COVERAGE AS WELL AS EXPERIMENTING WITH DIFFERENT WINDOW SHADING STRATEGIES.

FINAL ITERATION

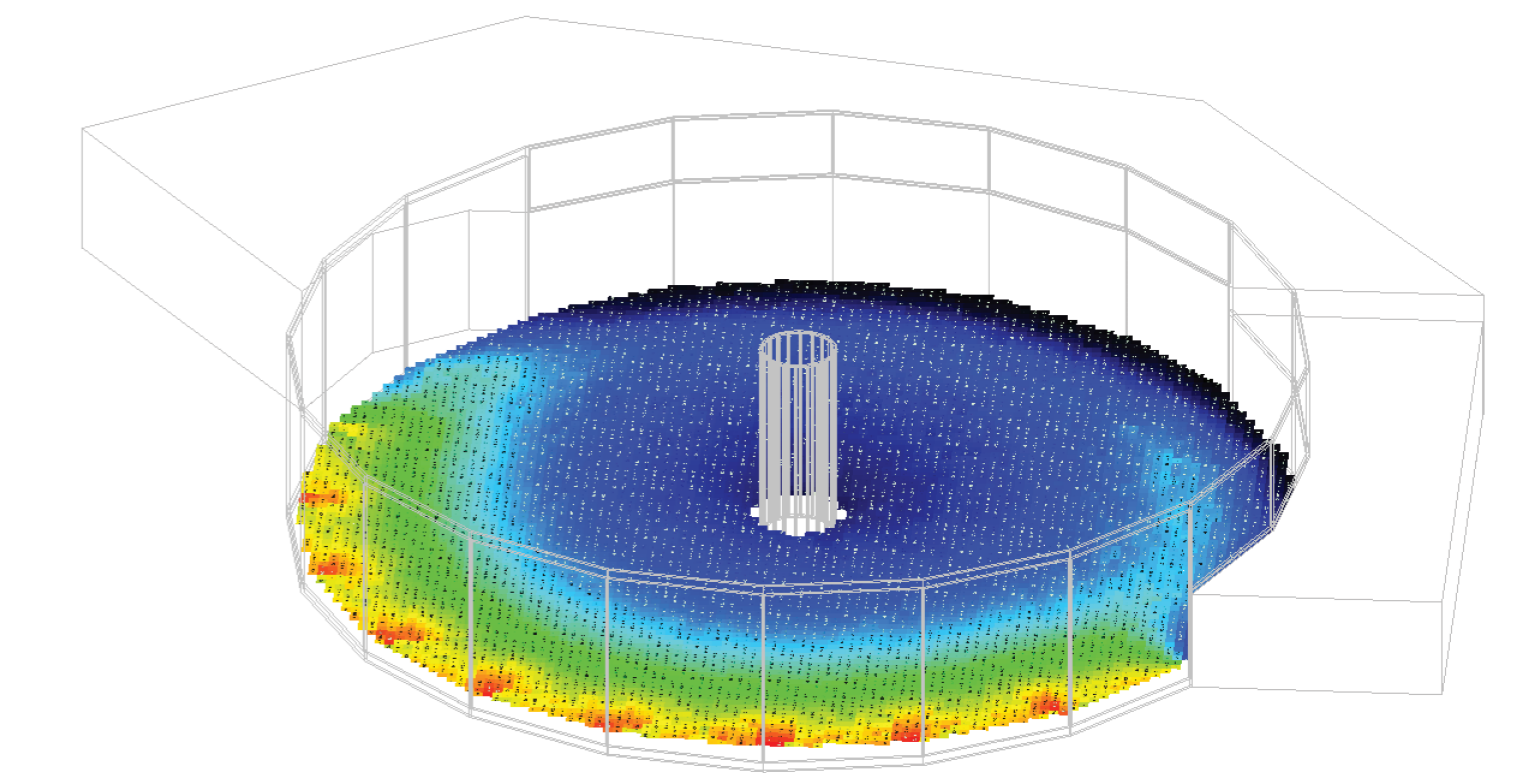
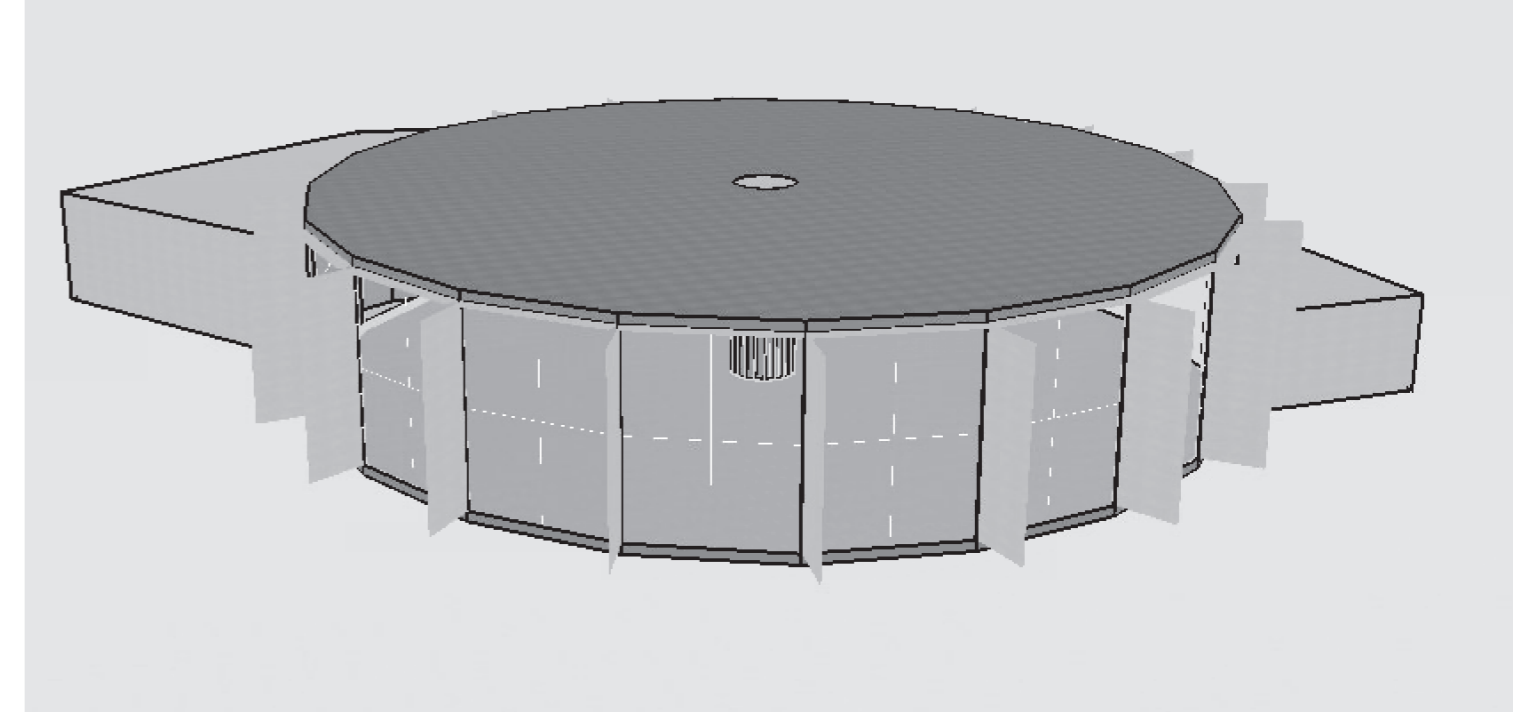

WINDOW SHADING: TRANSPARENT INSULATION
LOCAL SHADING: ONLY SINGLE SIDEFINS (2 m)
GLAZING TYPE: TRIPLE GLAZING, 100% FITTED GLAZING
GLAZING SPECIFICATION: SageGlass Climatop Blue No Tint
U-VALUE: 0.687 W/m²-K

AVERAGE DAYLIGHT FACTOR = 4.845%

SUNPATH DIAGRAM

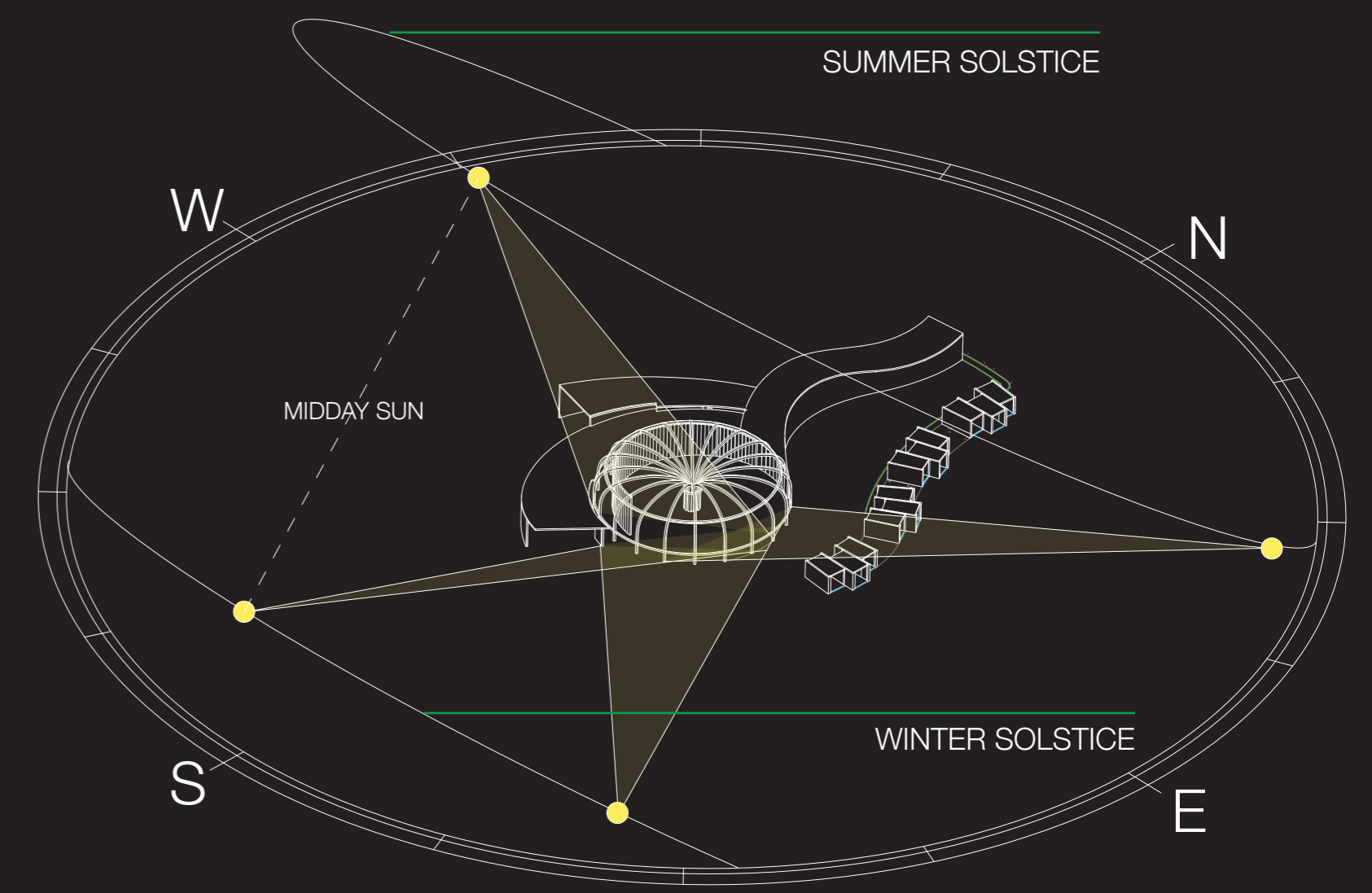

FINAL SHADING DESIGN STRATEGY

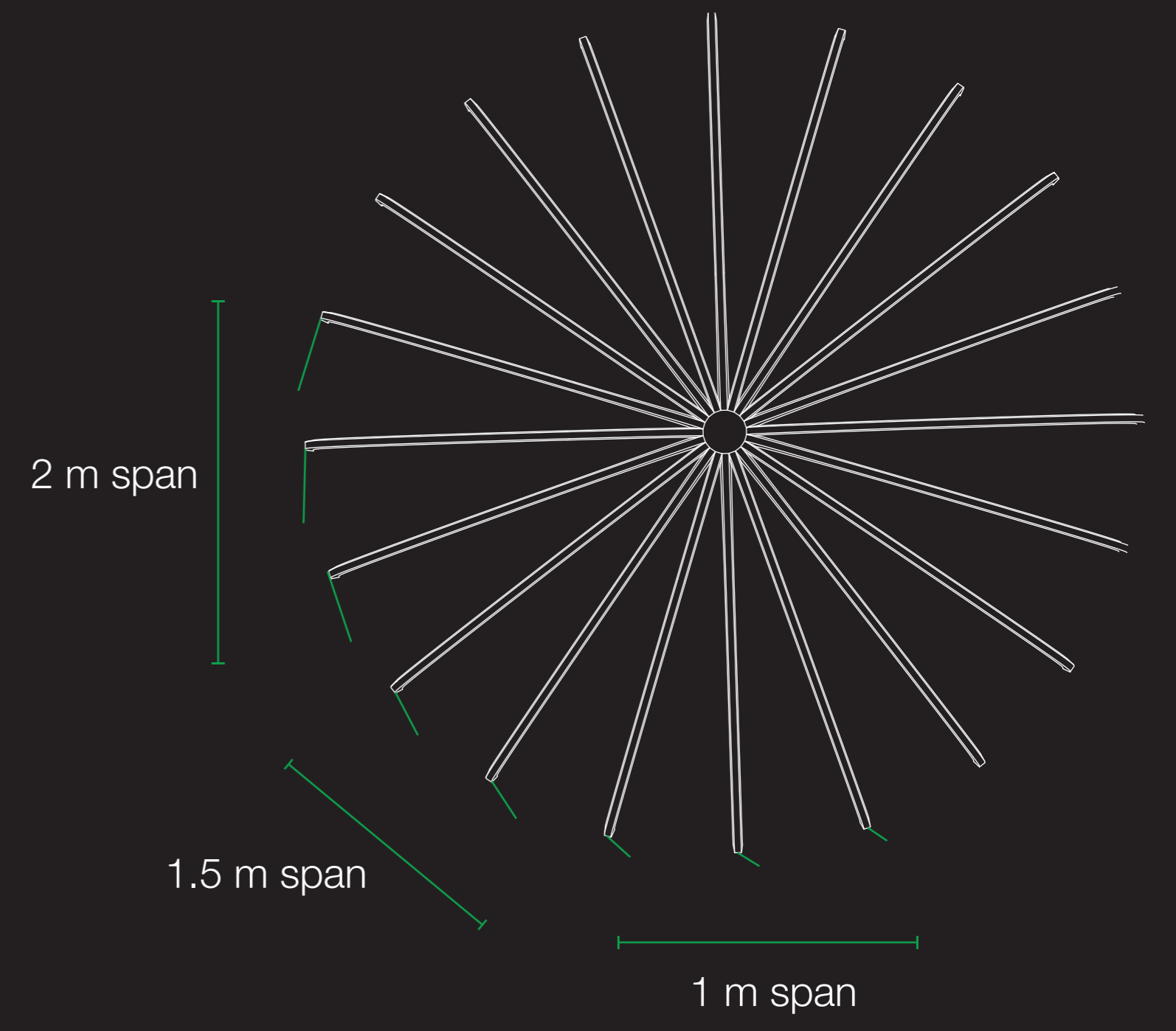

USING THE SUN PATH DIAGRAM TO DESIGN VERTICAL SHADING DEVICES FOR THE SOUTH-EASTERN FACADE OF THE BUILDING

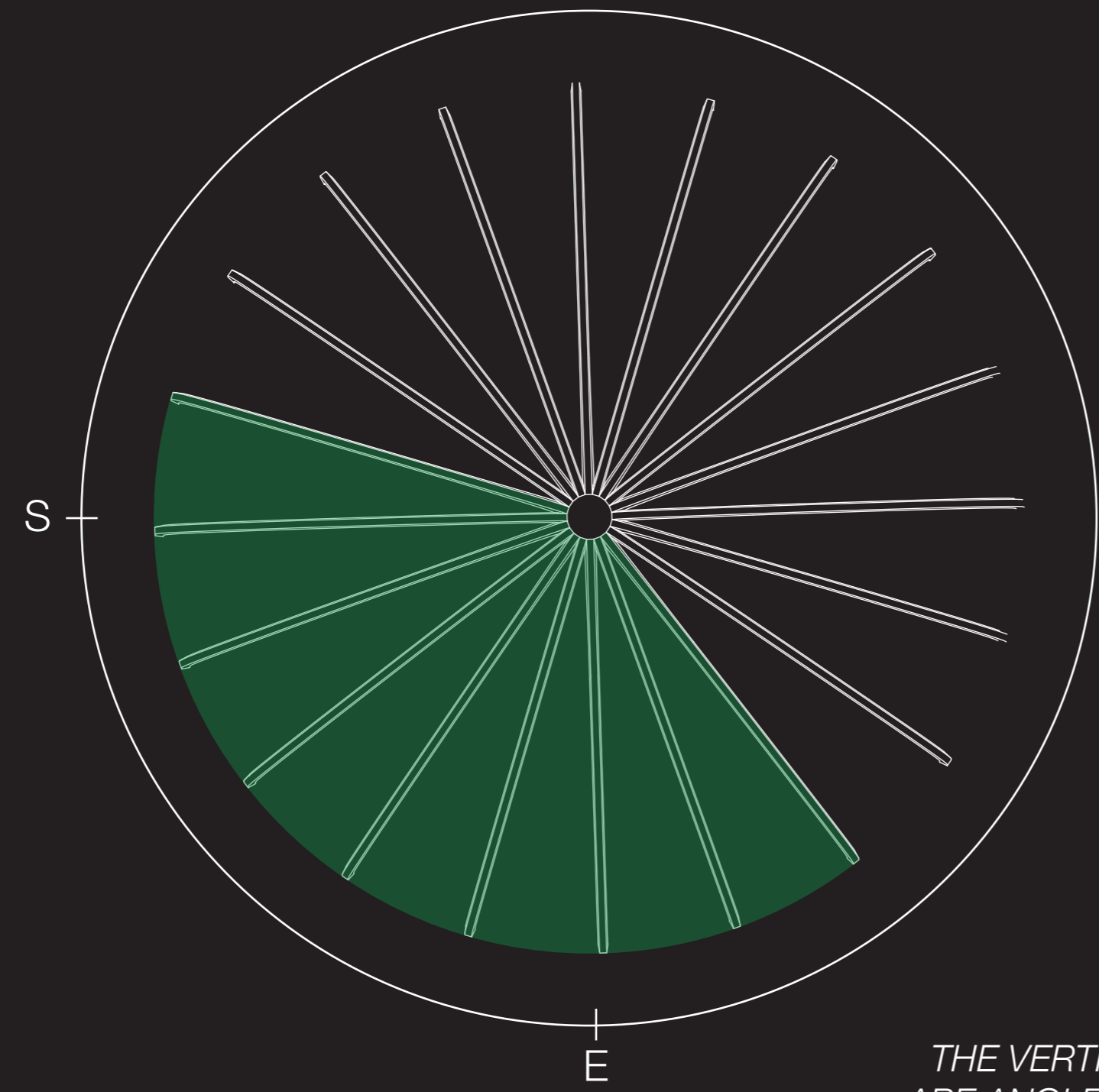
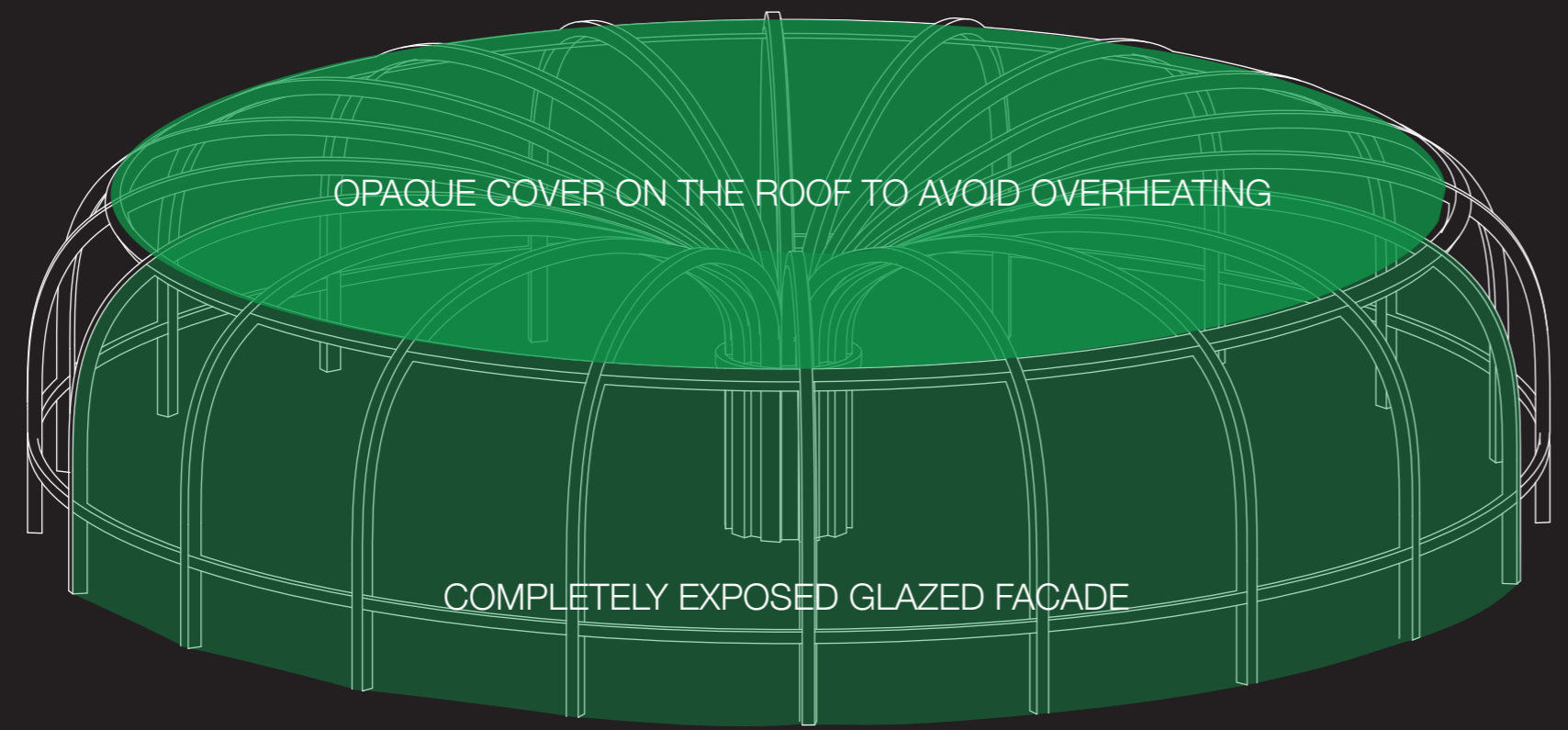

THE VERTICAL LOUVRES ARE ANGLED TO PROVIDE MAXIMUM SHADING FROM THE SOUTH SUN WITH MINIMAL INVASION OF EAST SIDE VIEWS

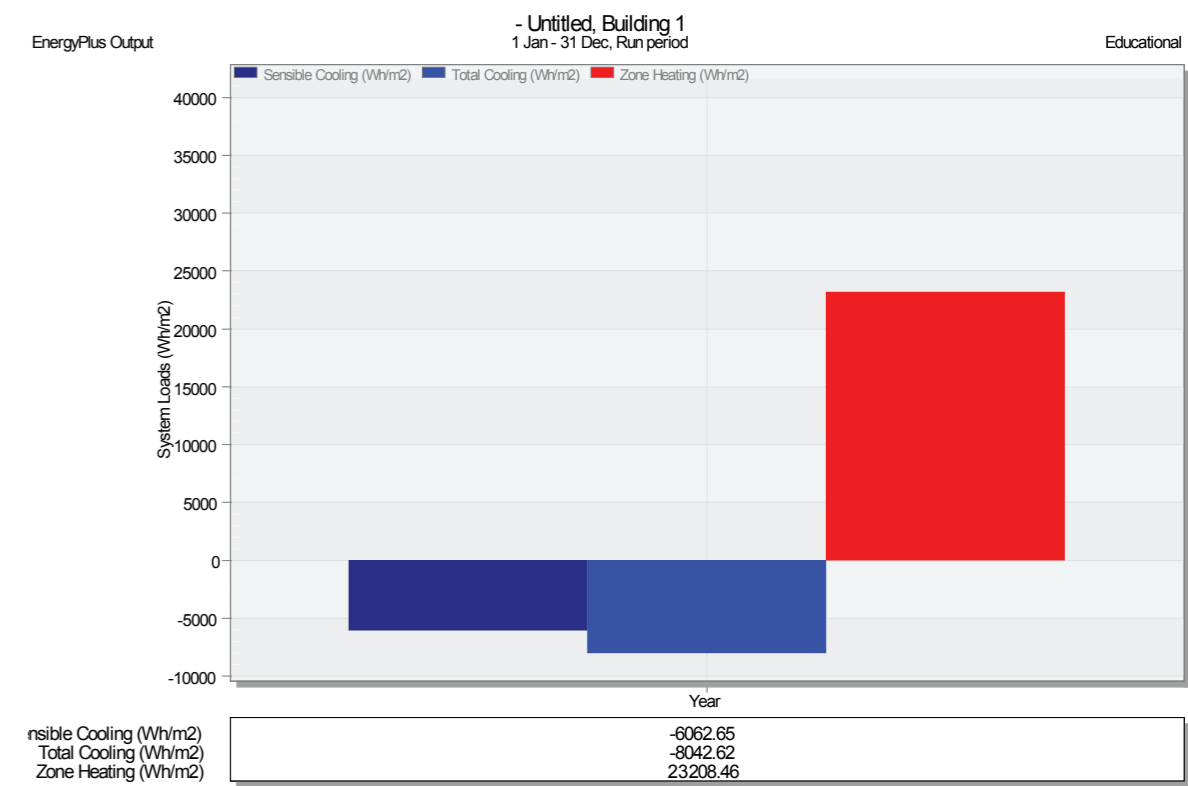
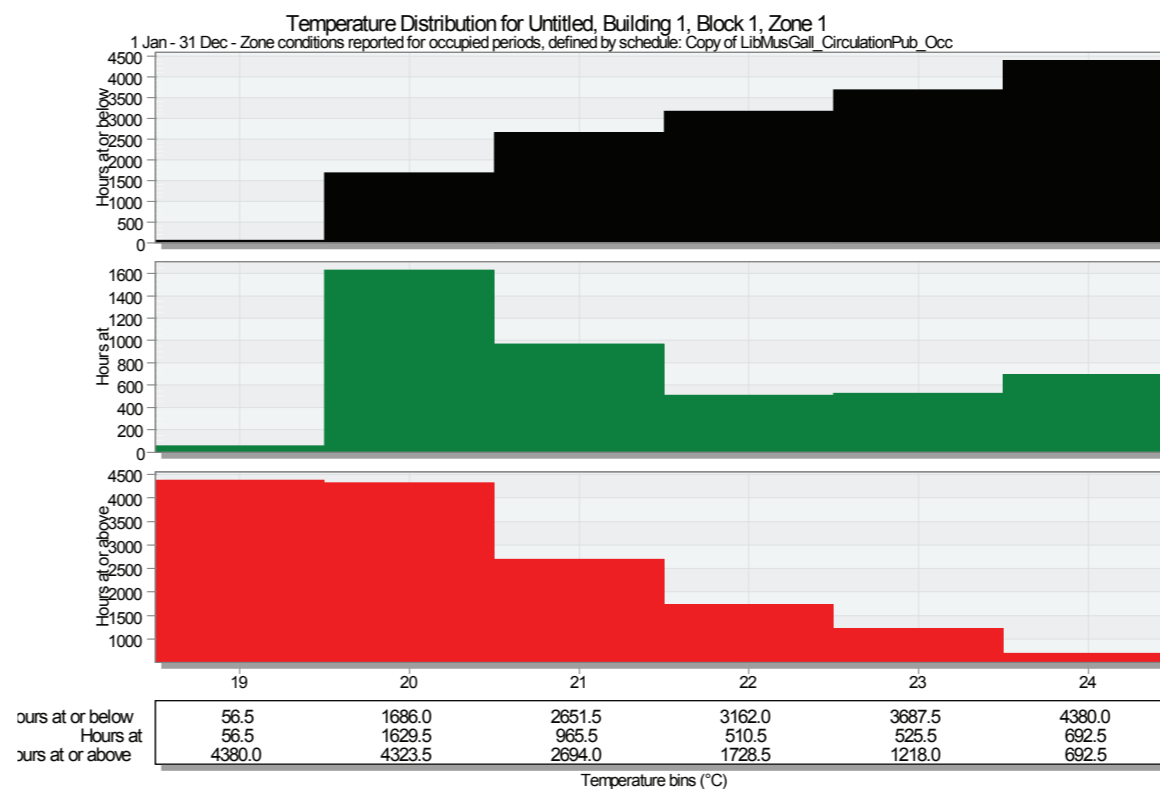
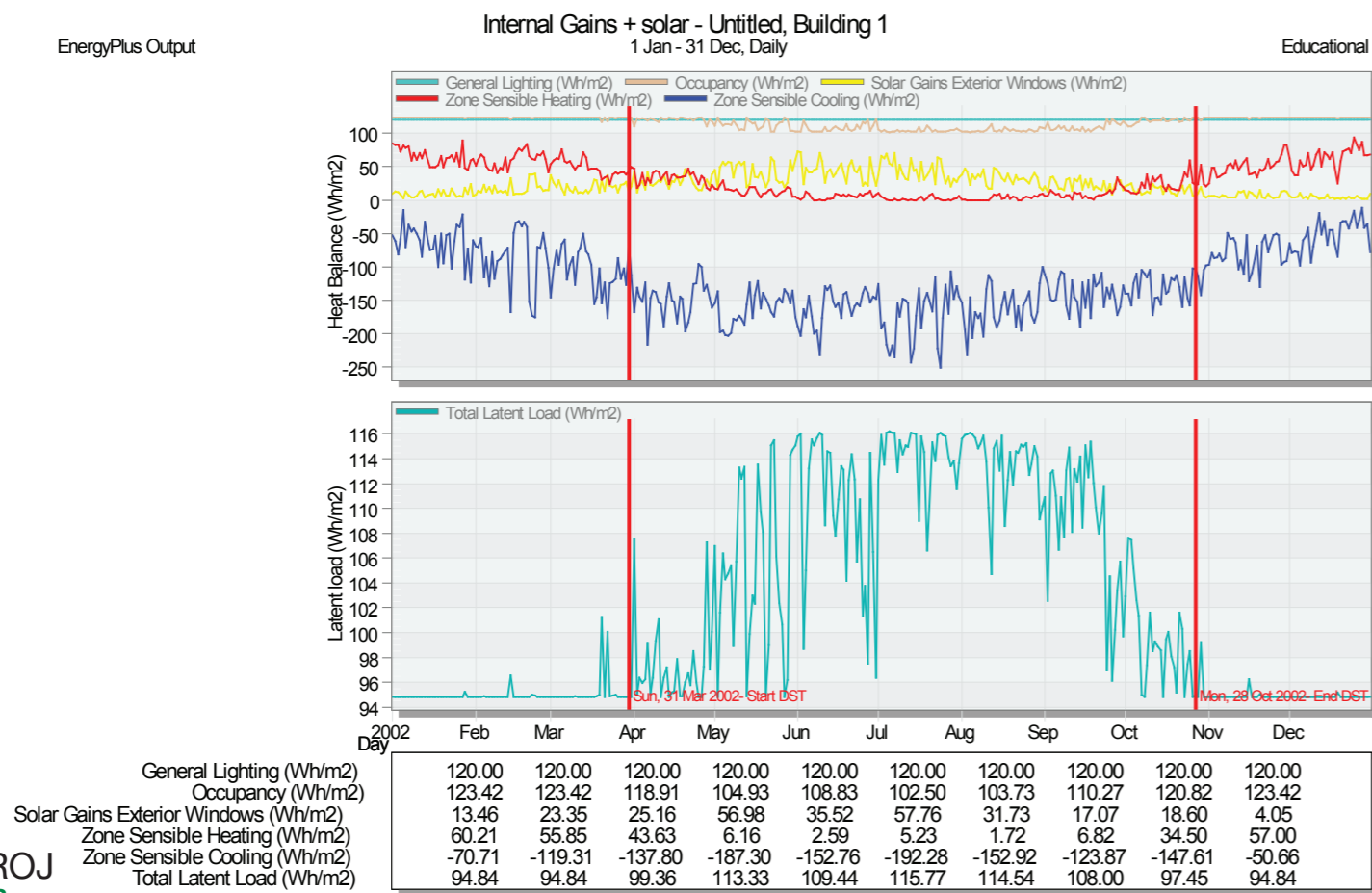
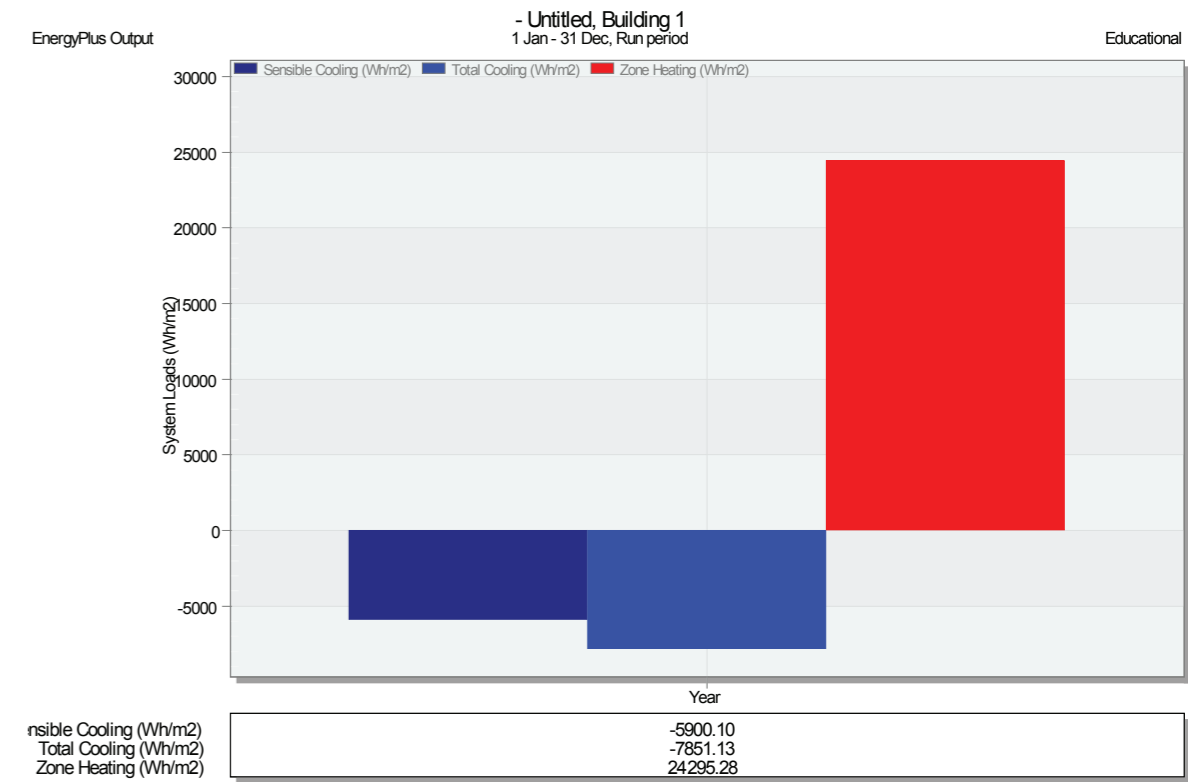
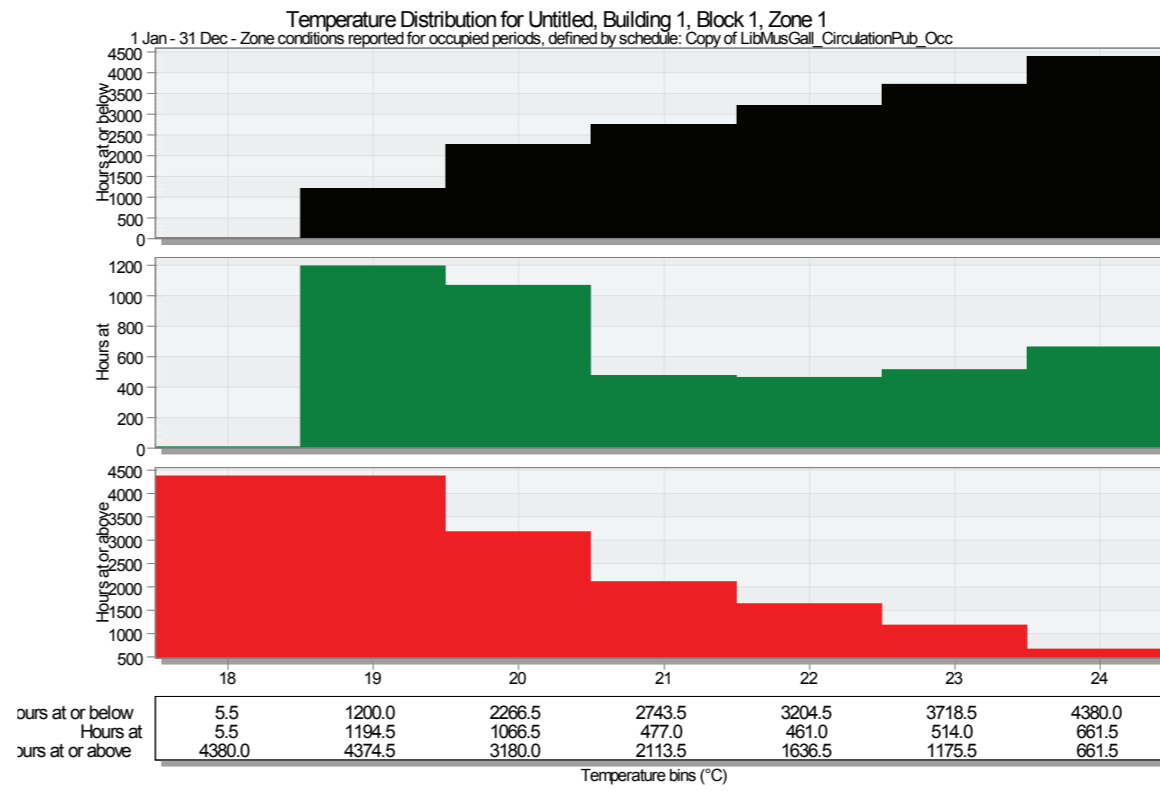
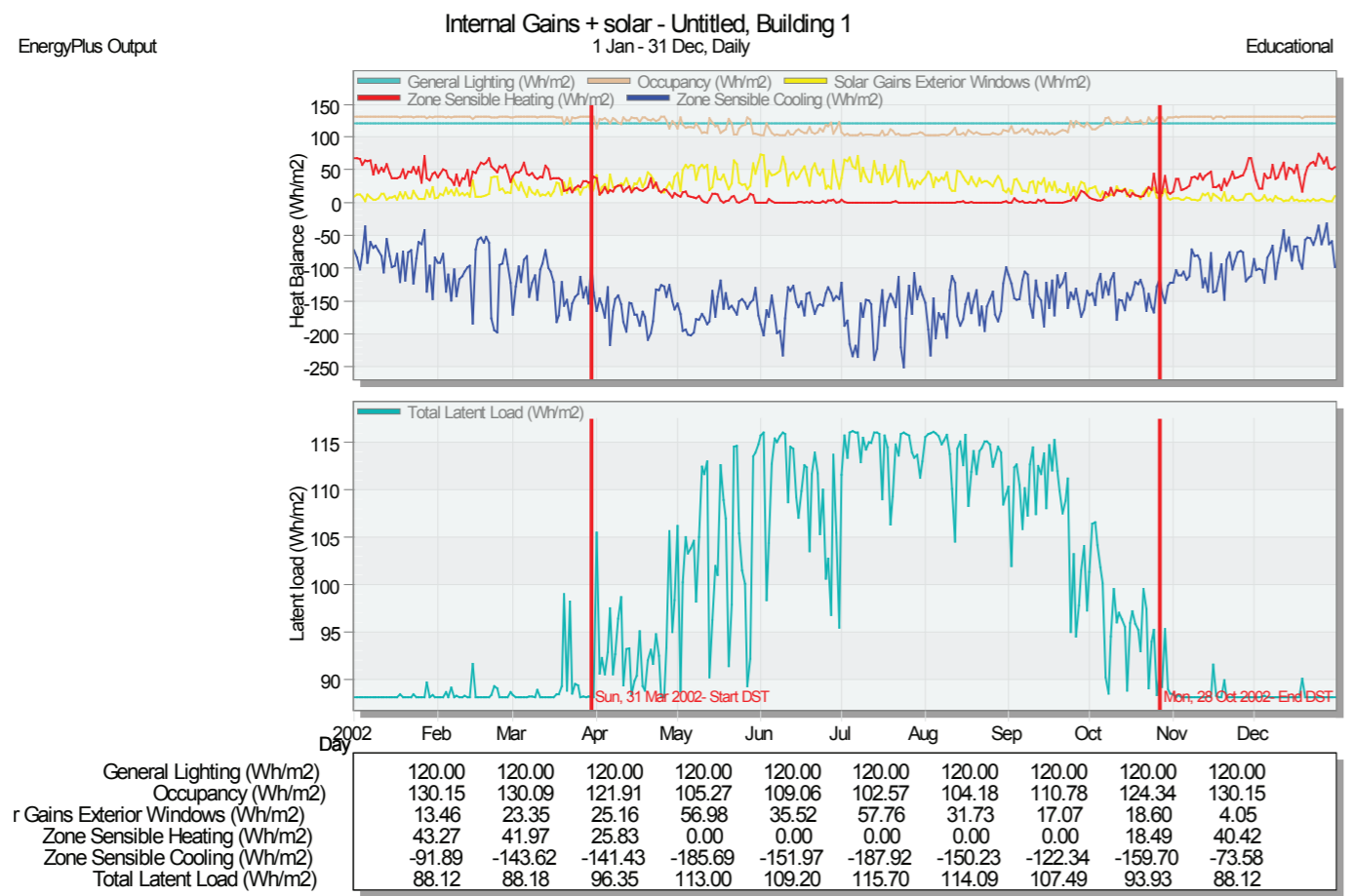
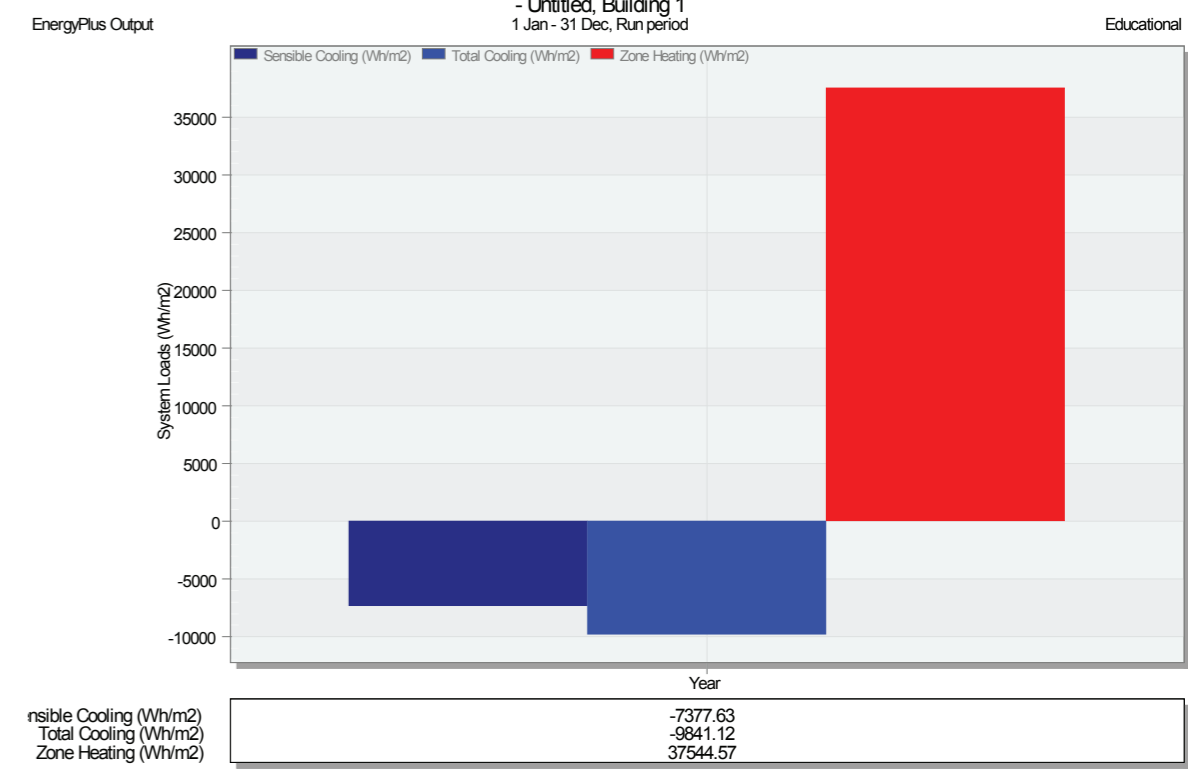
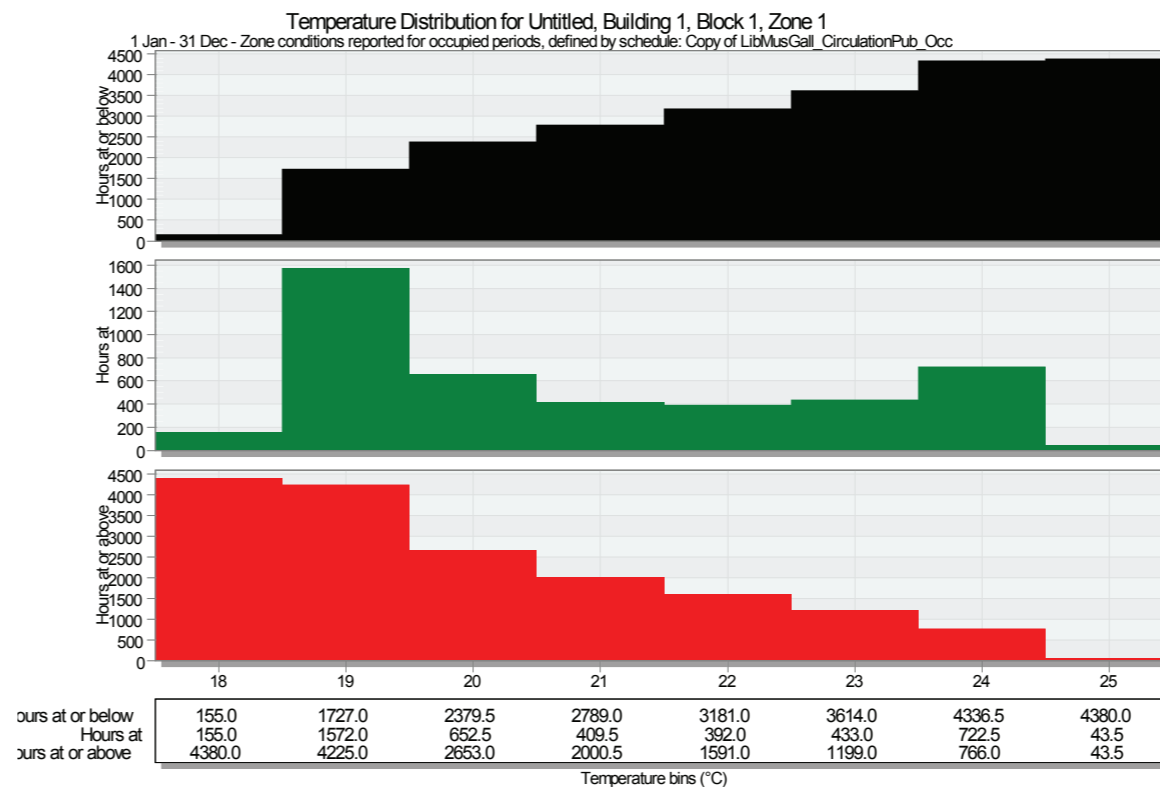
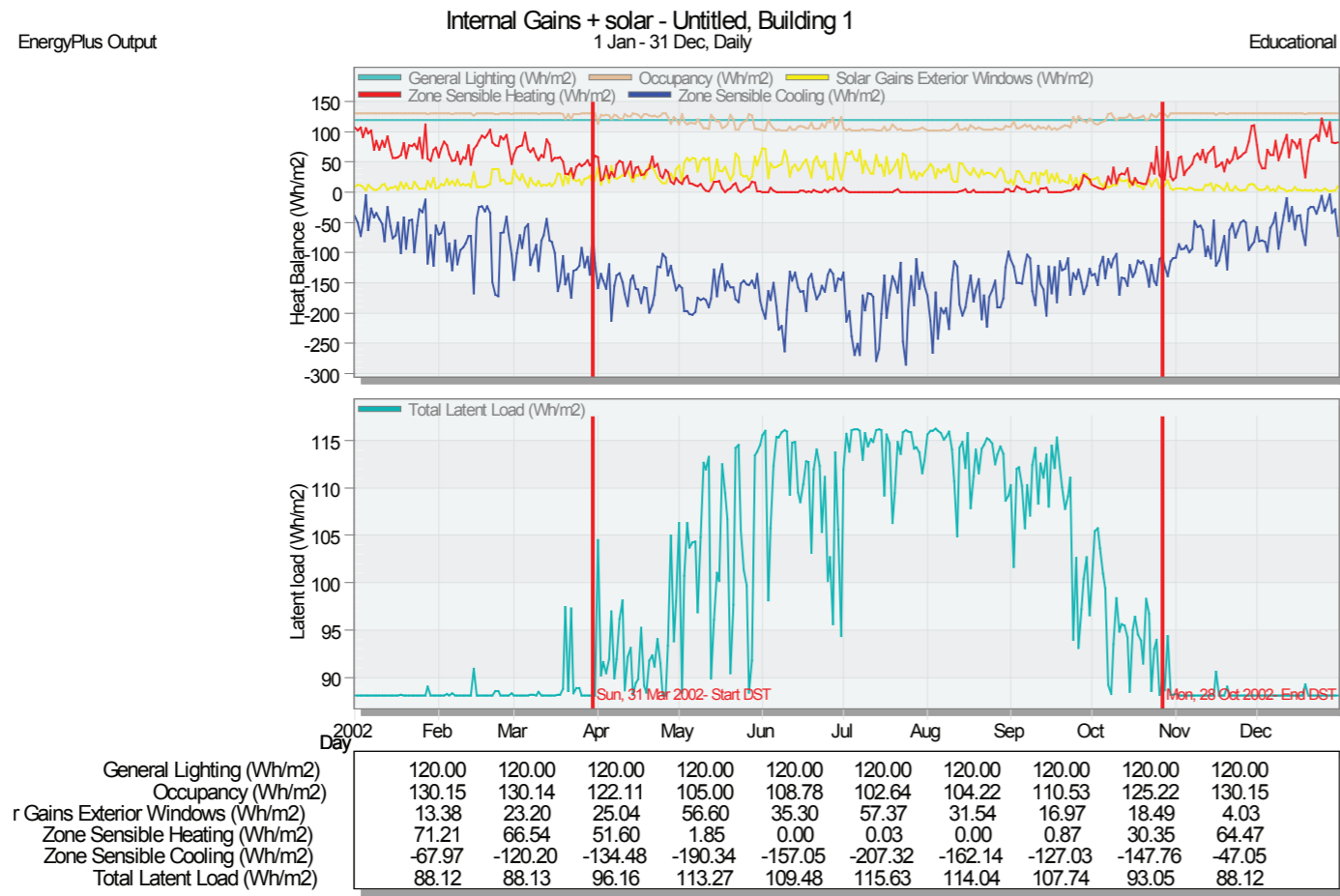

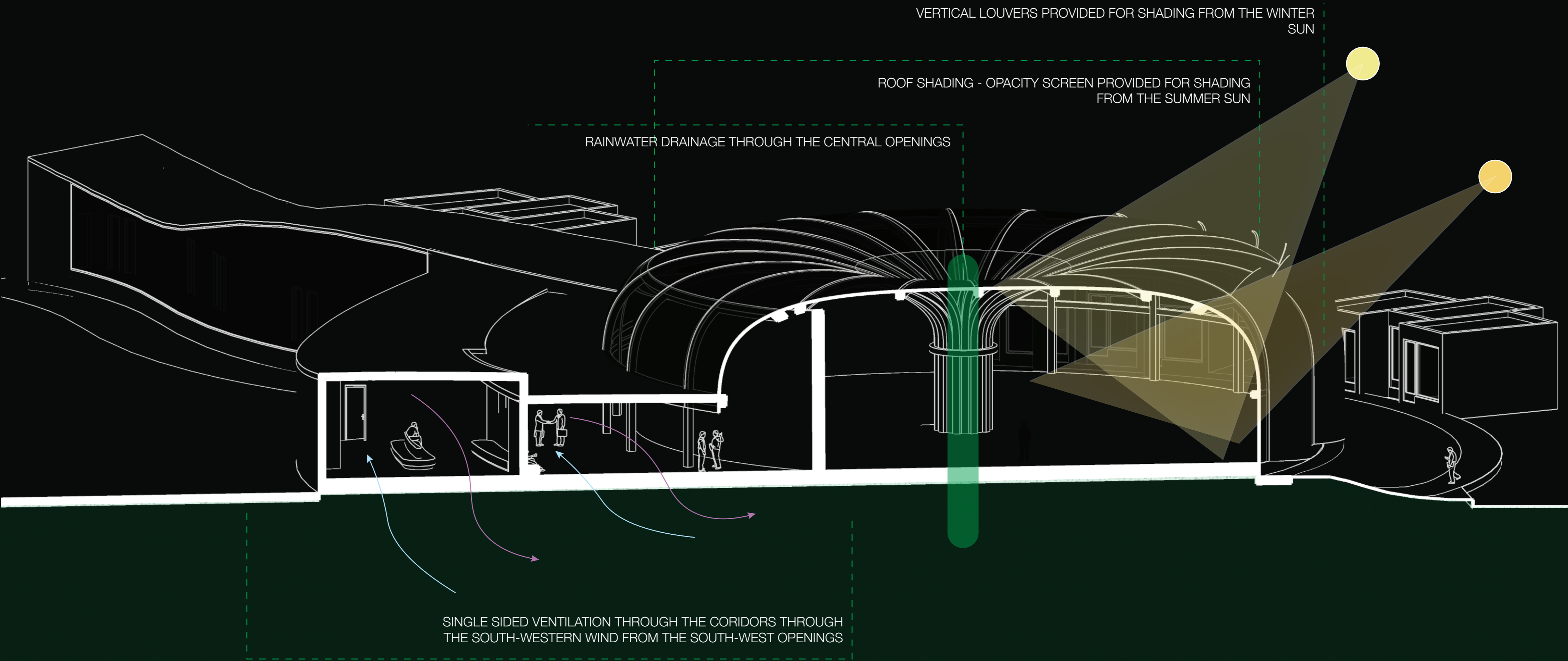



STRUCTURAL CONSIDERATIONS

FINDING THE STRUCTURAL FORM OF THE TIMBER STRUCTURE COVERING THE CENTRAL GALLERY SPACE



THE SPACE TO BE COVERED IS CIRCULAR
DIA = 31.68 m
FLOOR AREA = 790 m²
MAXIMUM DESIRED SPATIAL HEIGHT = 7m

THE REQUIREMENT OF THE SPACE IS TO
MAXIMISE SPATIAL GLAZING SO THE FRAME
OF THE STRUCTURE MUST BE SPARSE TO
ALLOW FOR VIEWS THROUGH THE GRID.

ITERATION 1

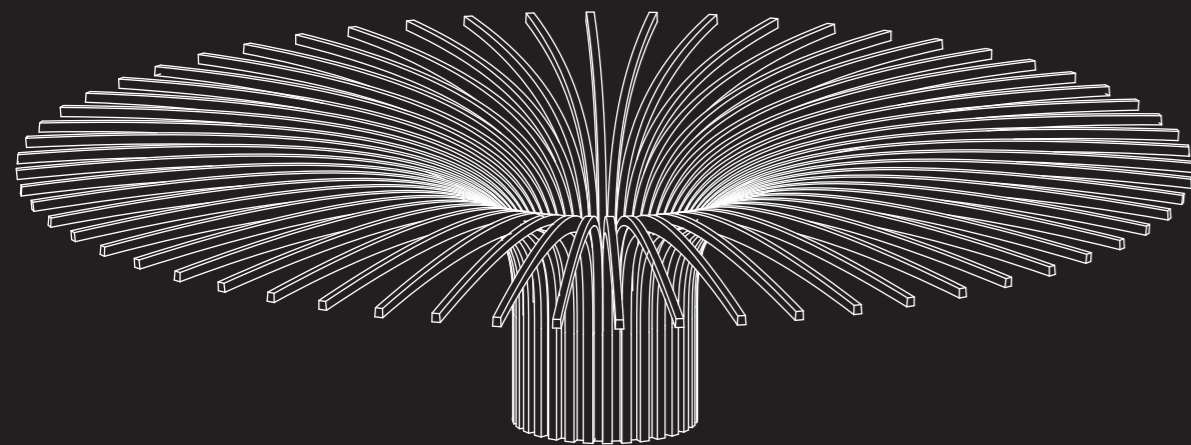

FRAME COVERS ONLY THE ROOF AND THE HORIZONTAL
MEMBERS ARE CANTILEVERED

ITERATION 2

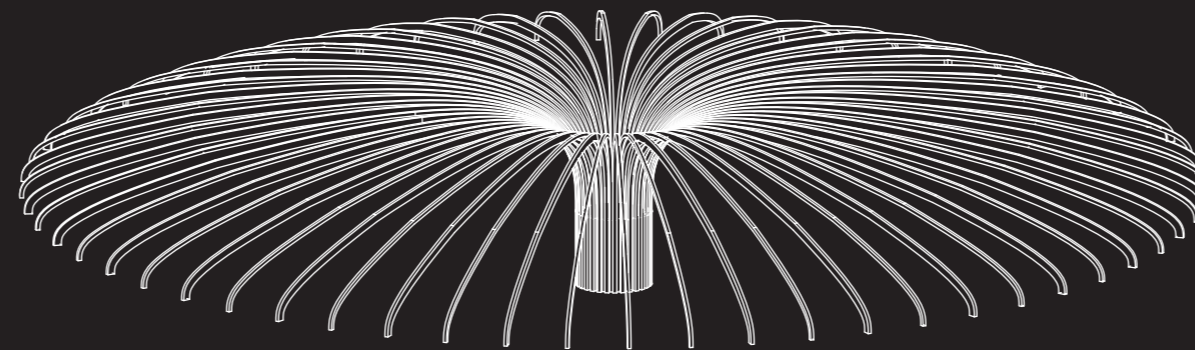

THE HORIZONTAL MEMBERS ARE ARCHED DOWNWARDS
BUT IT REDUCES OVERALL HEIGHT

ITERATION 3

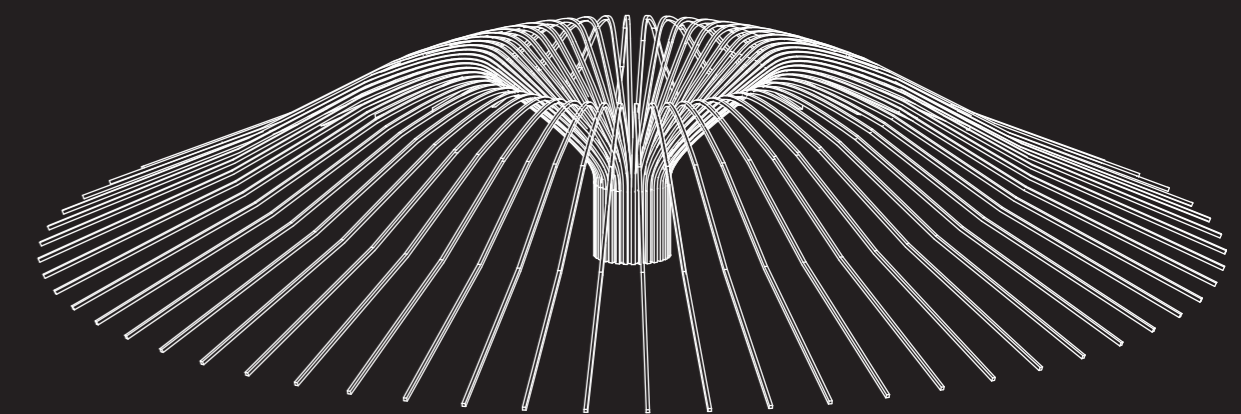

THE CURVATURE IS NOT SMOOTH AND THE RESULTANT
ARCH IS NOT STRUCTURALLY STABLE

ITERATION 4

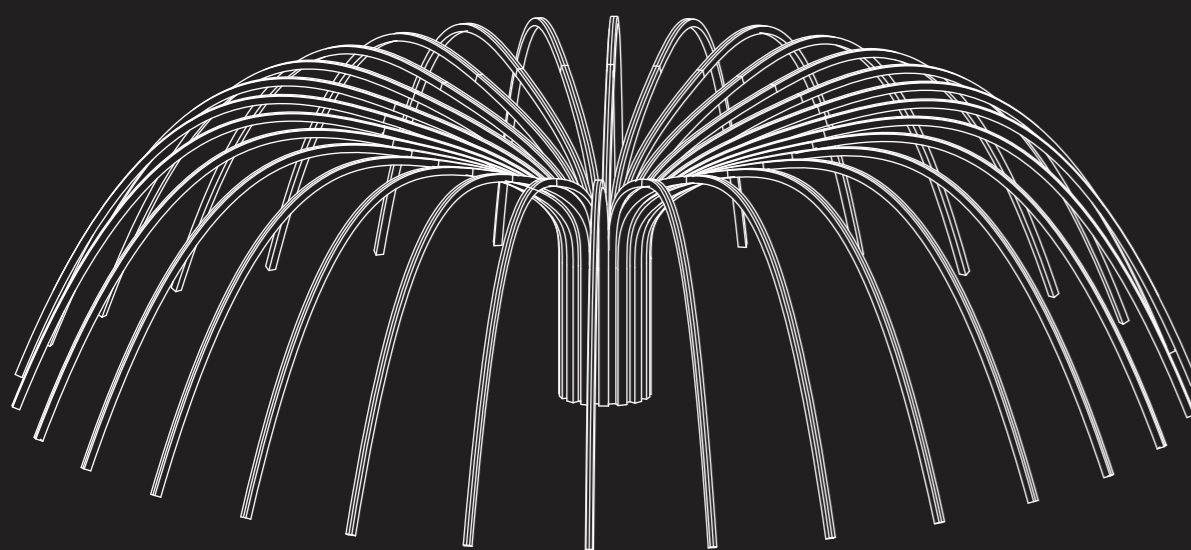

THE ARCH CURVATURE IS OPTIMISED AND THE GRID
MEMBERS ARE REDUCED

ITERATION 5

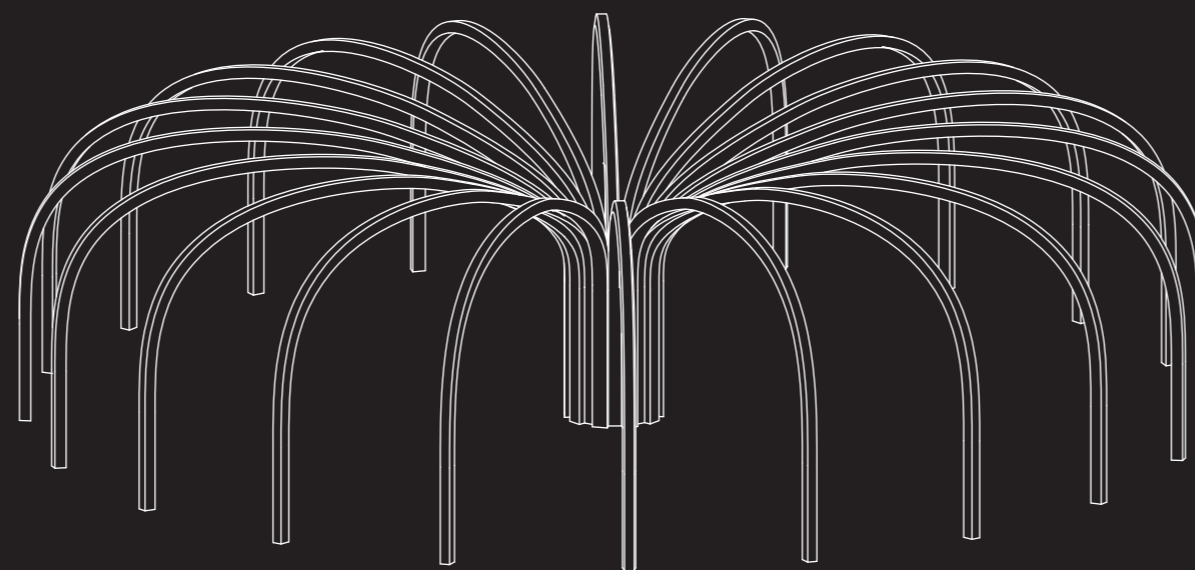

THERE IS 2.5 m OF VERTICAL LENGTH OF MEMBERS
ALONG THE PERIMETER FOR STABILITY

ITERATION 6

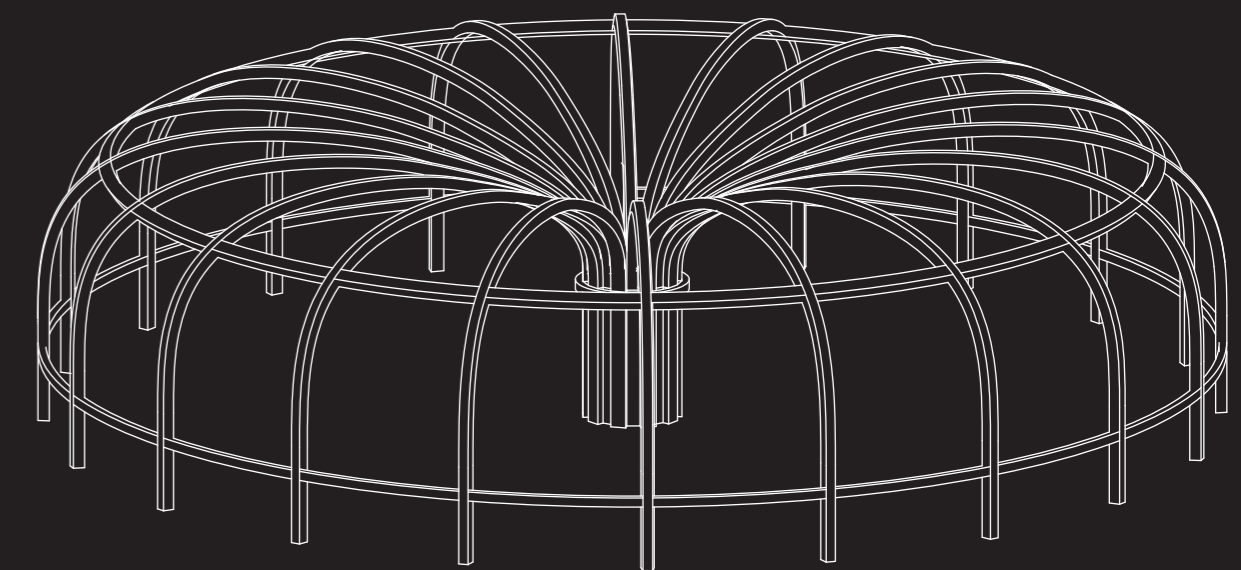

HORIZONTAL BRACINGS ARE ADDED TO THE GRID TO
INCREASE STRUCTURAL STABILITY

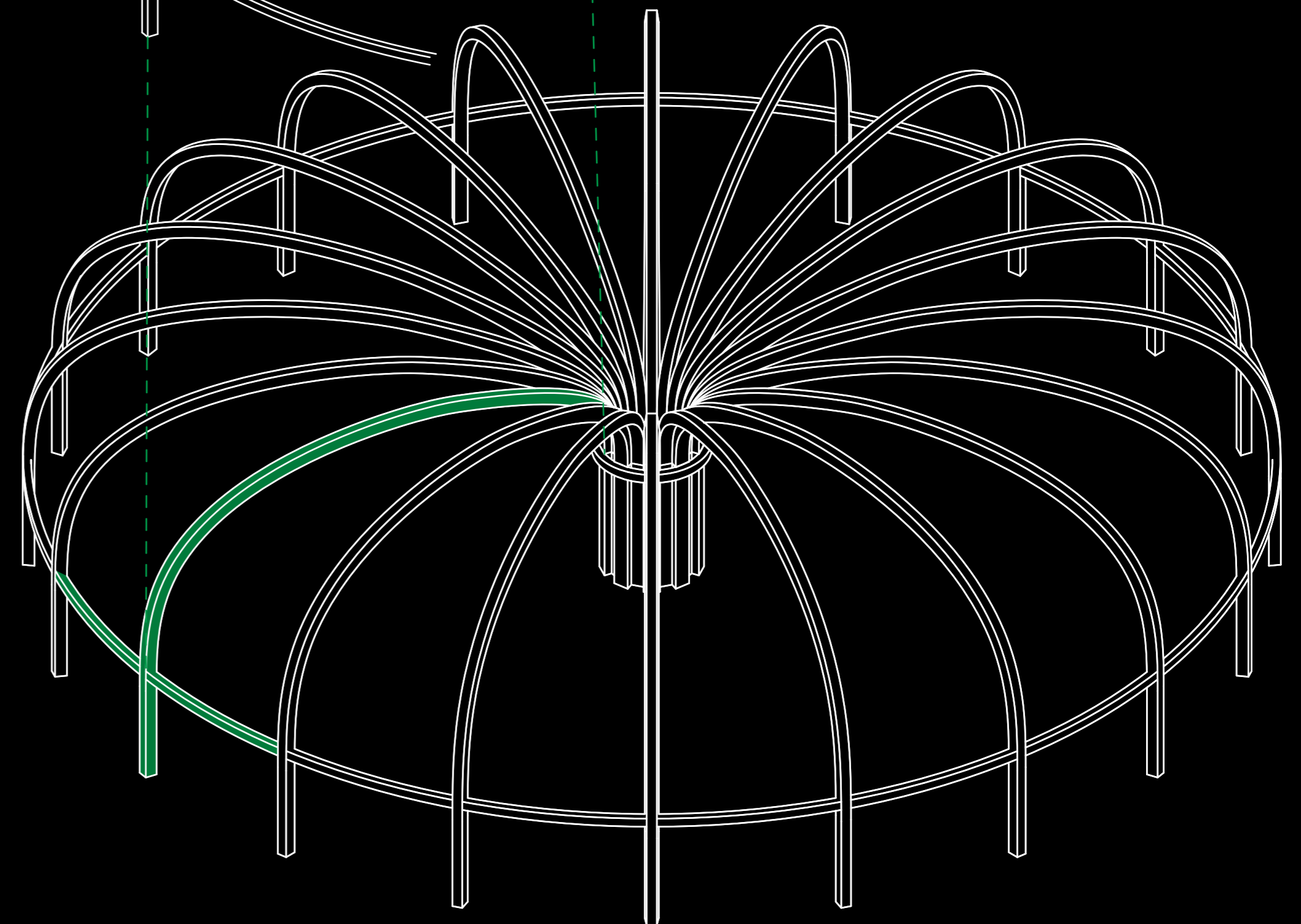
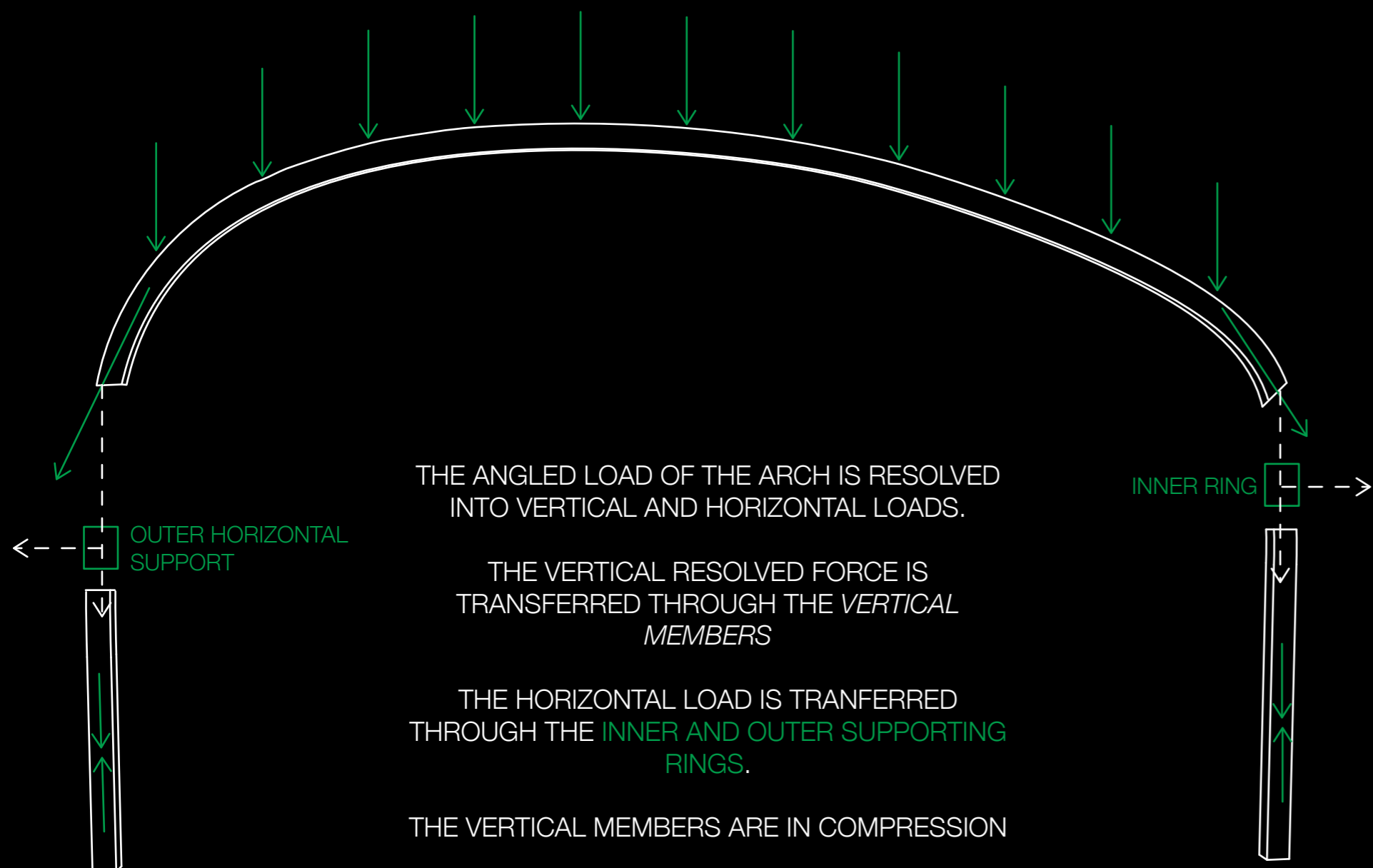
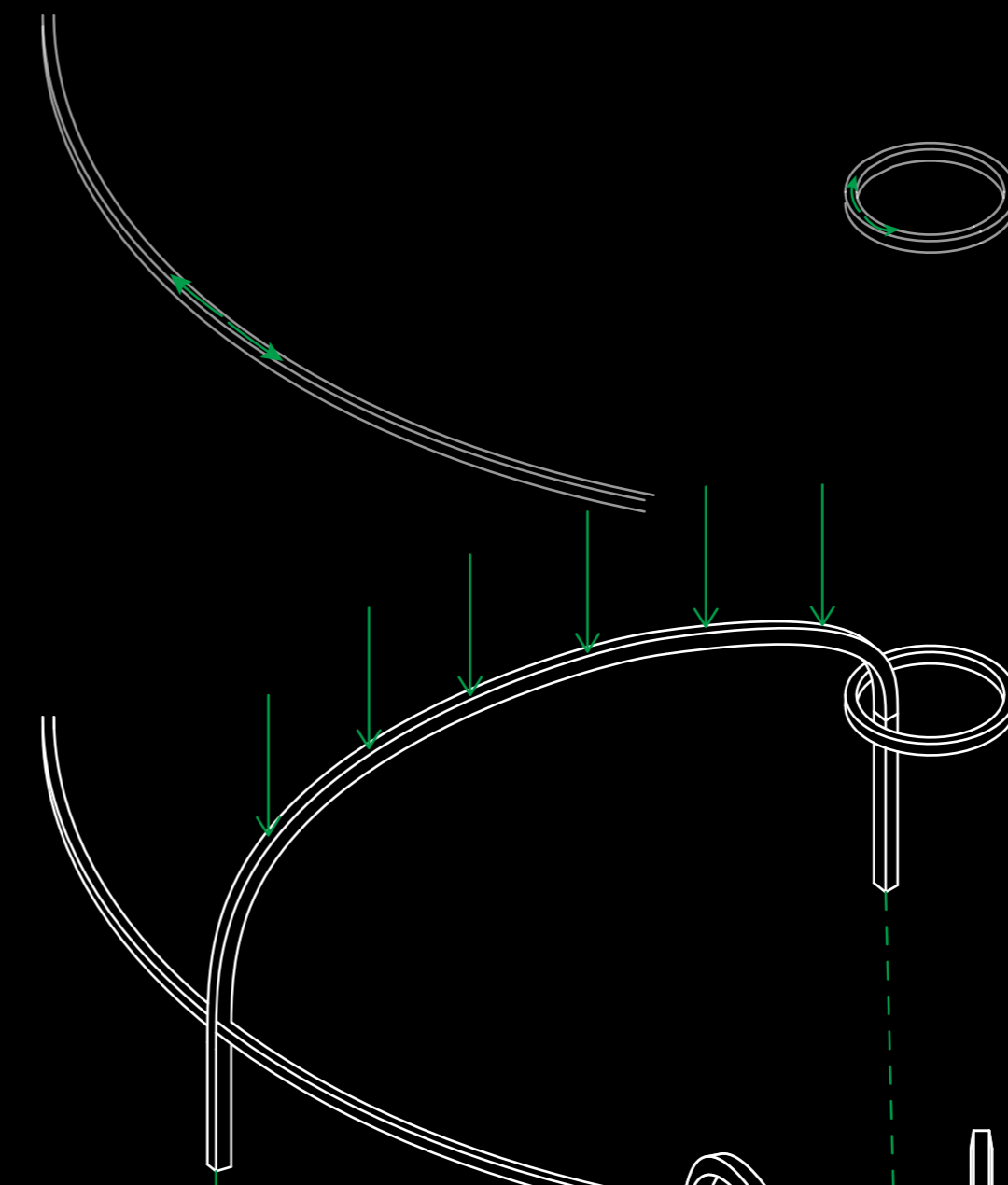
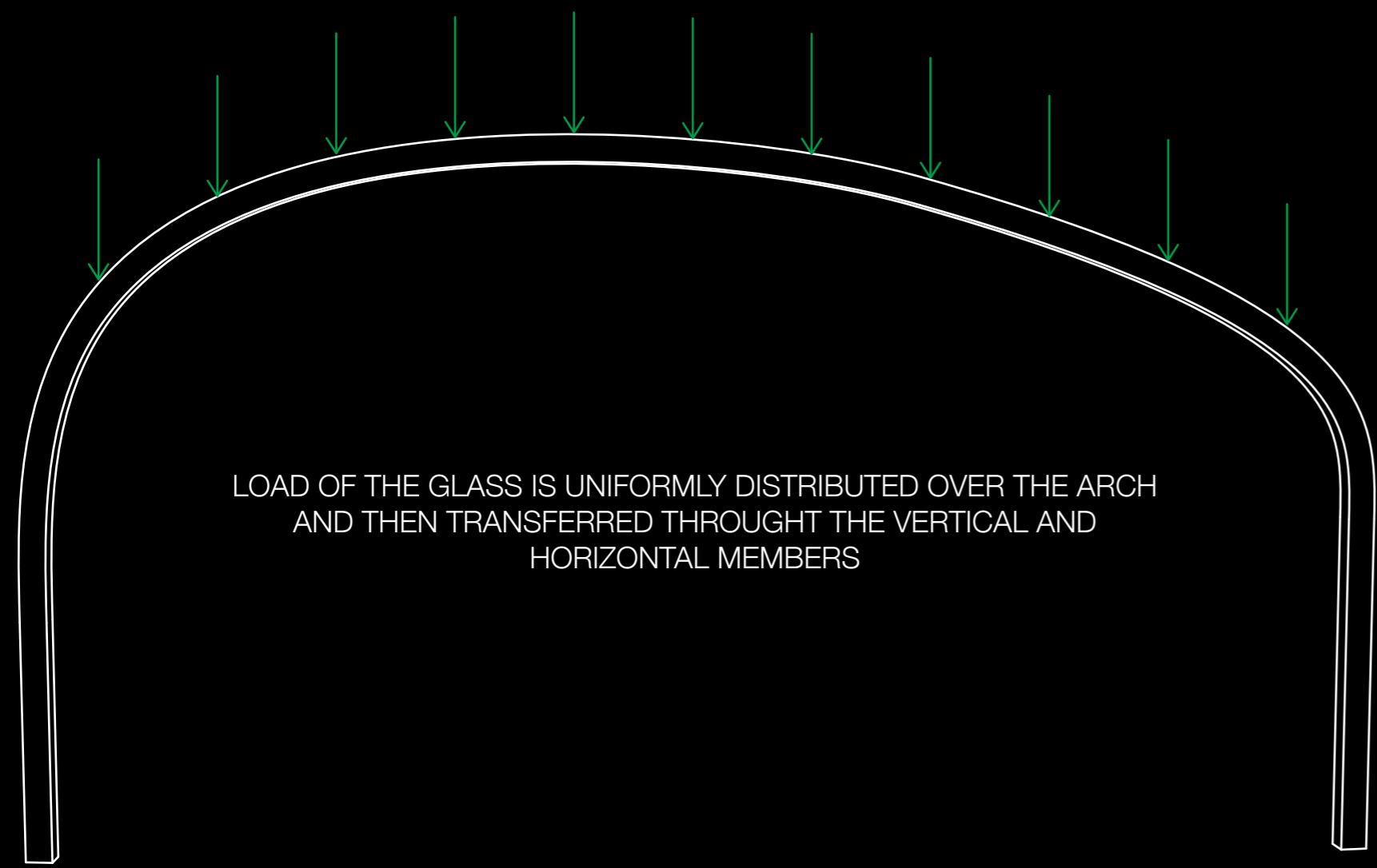

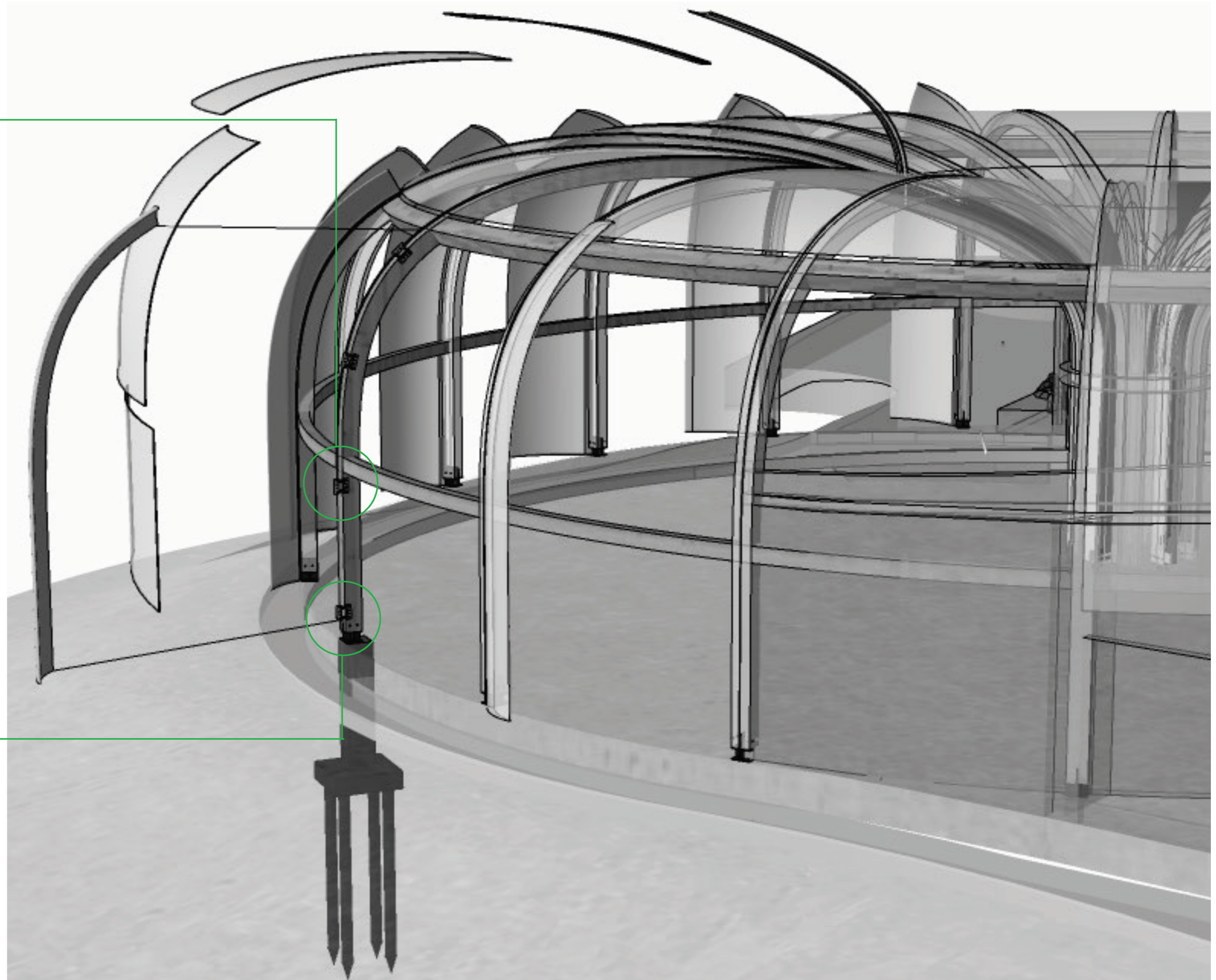
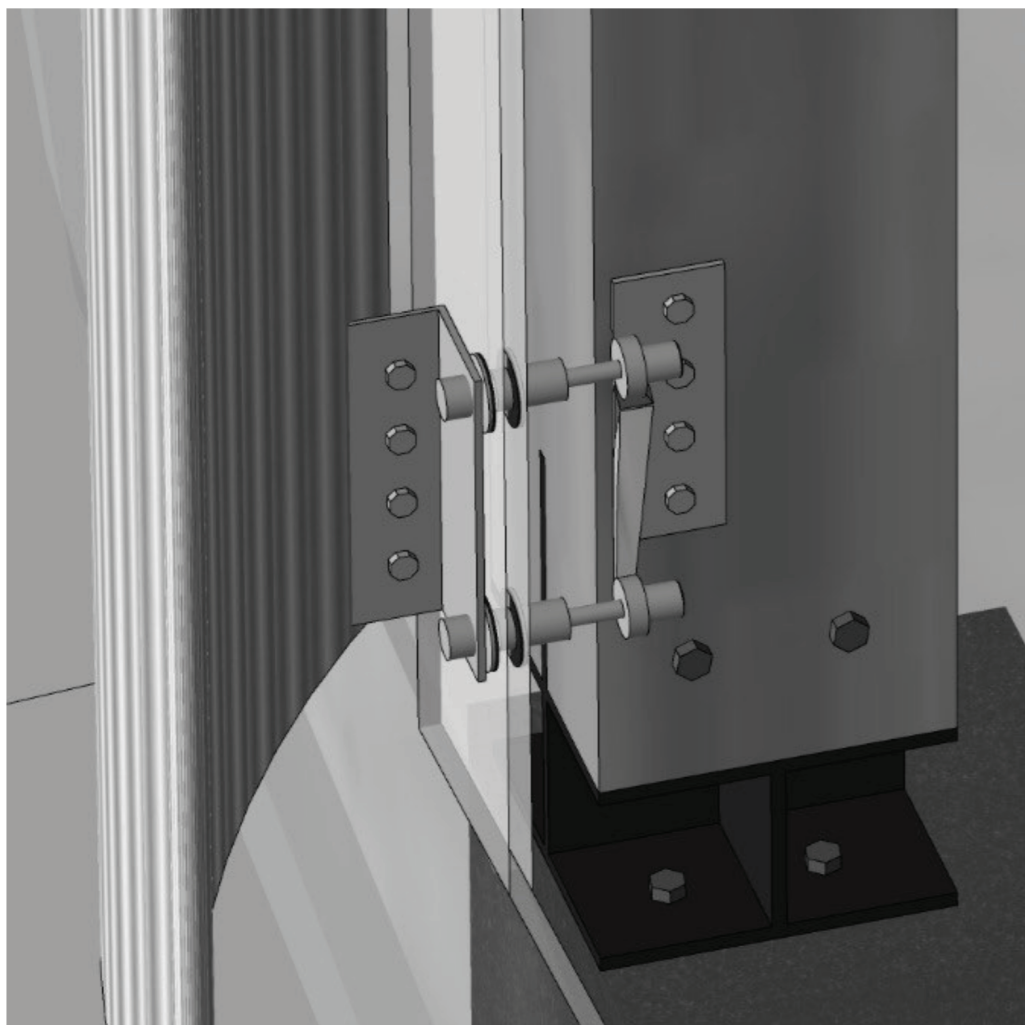
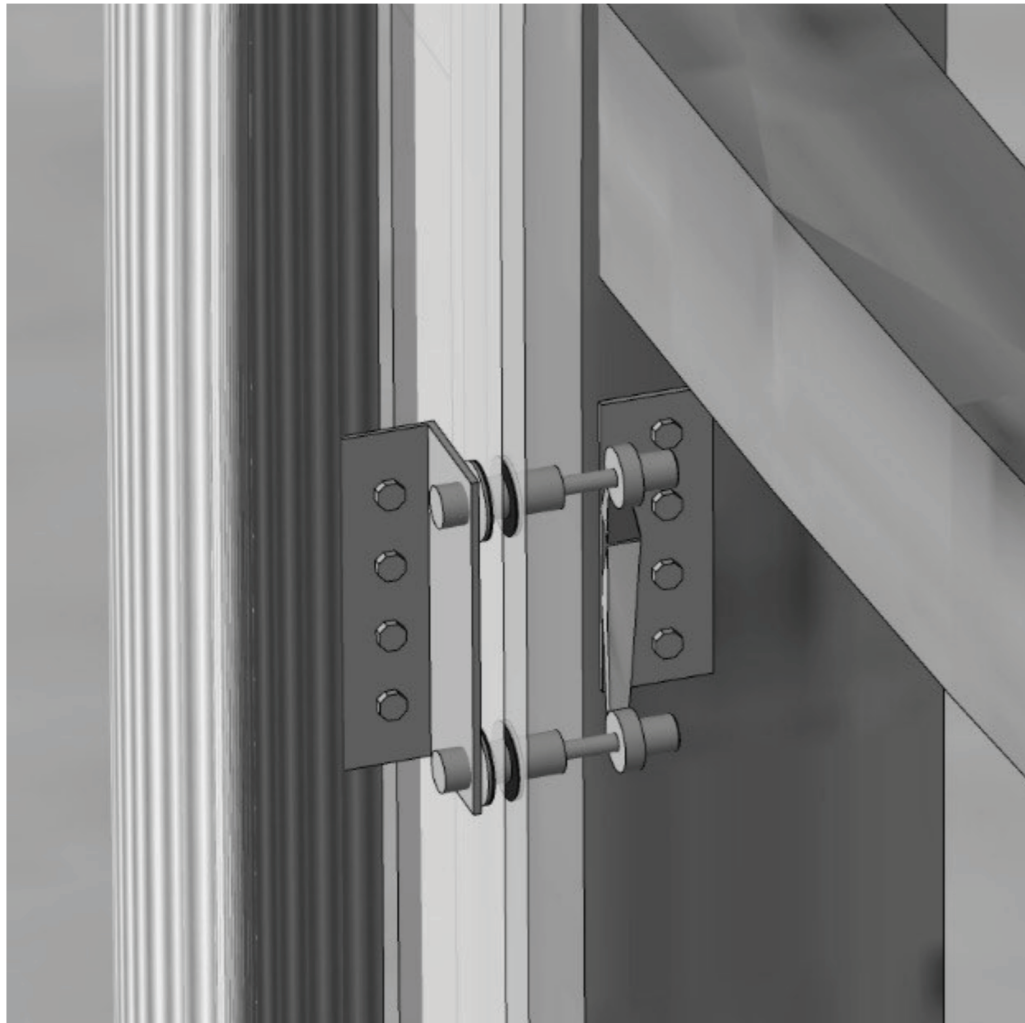

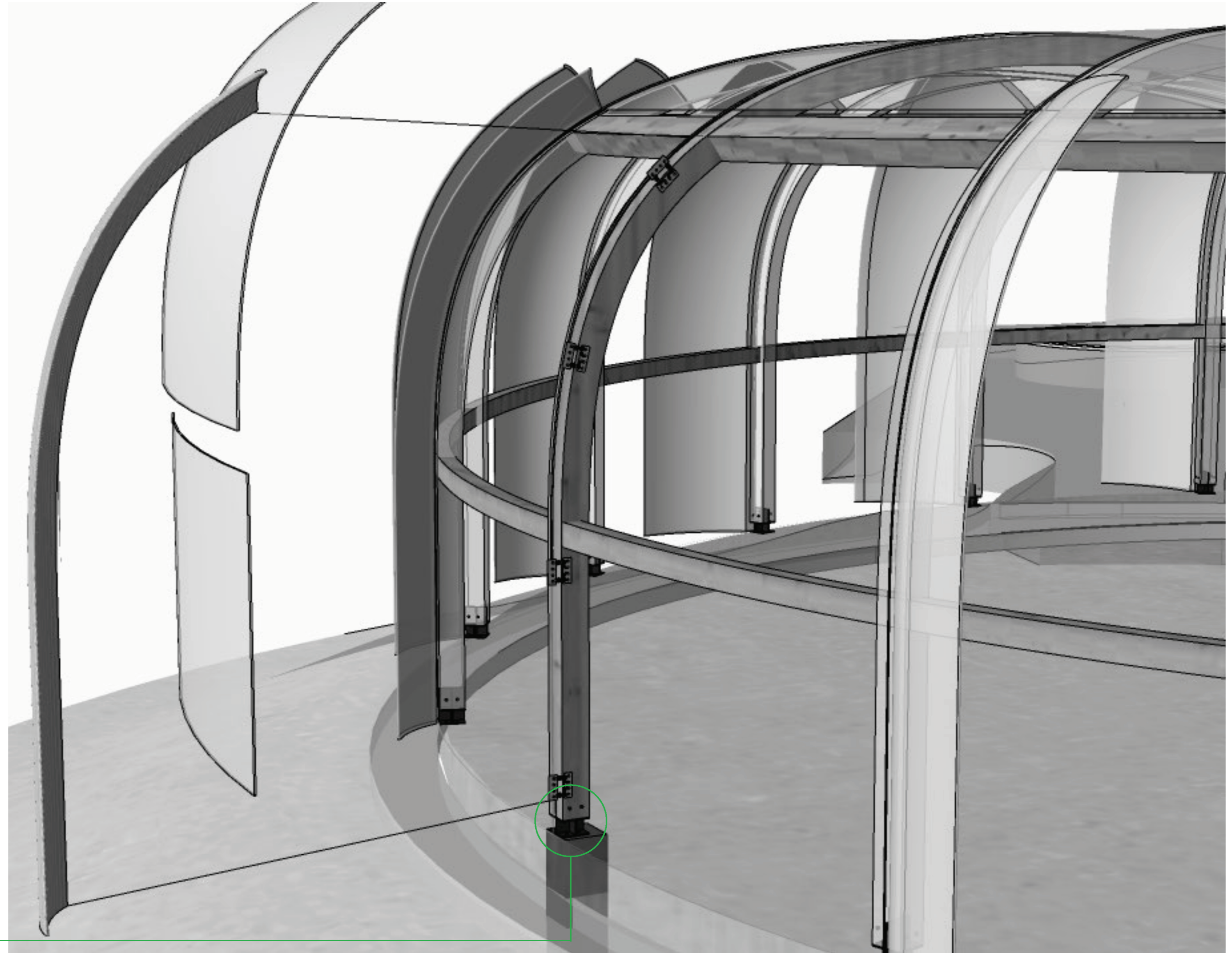
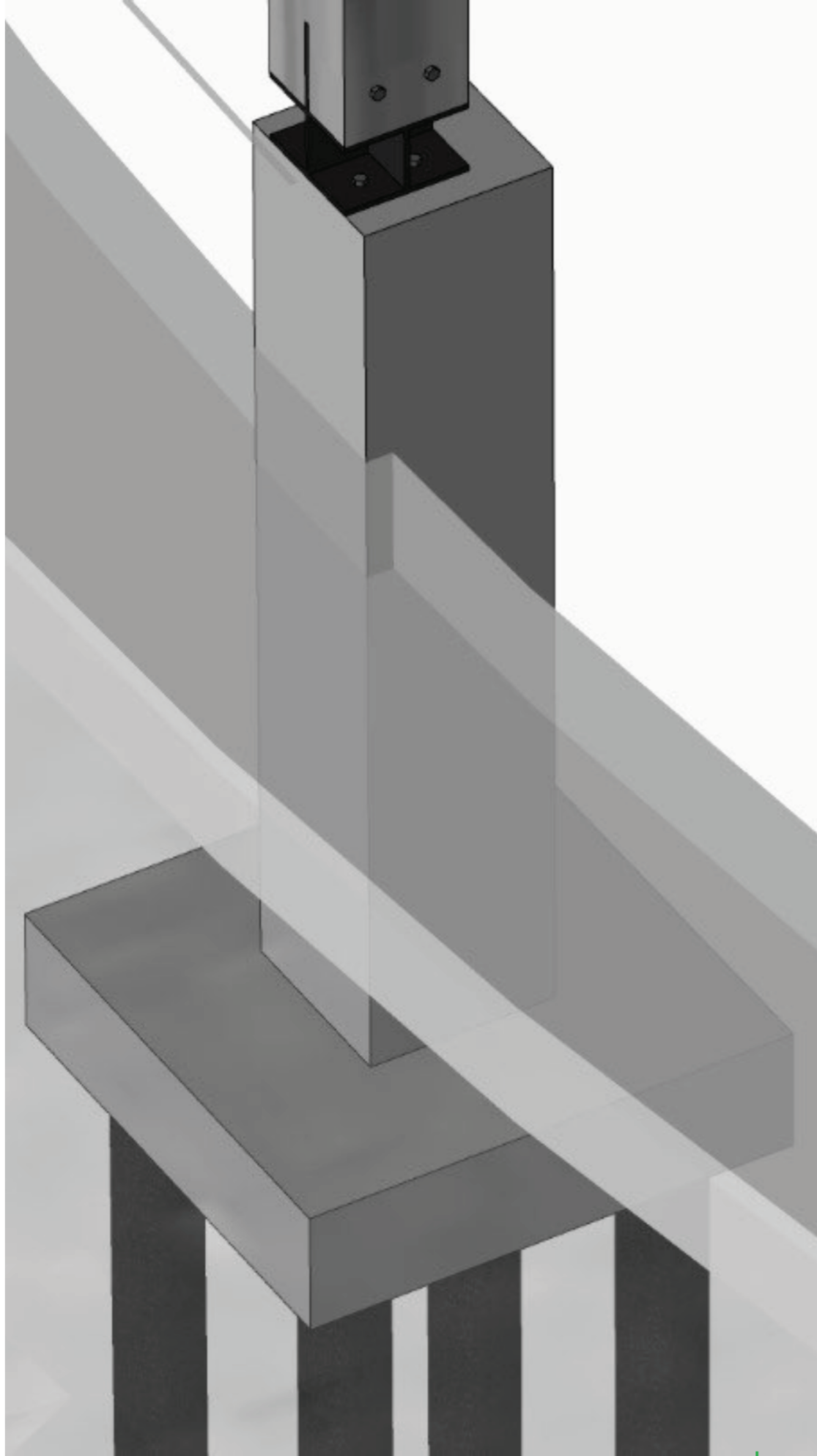



EXTERNAL RENDERS

















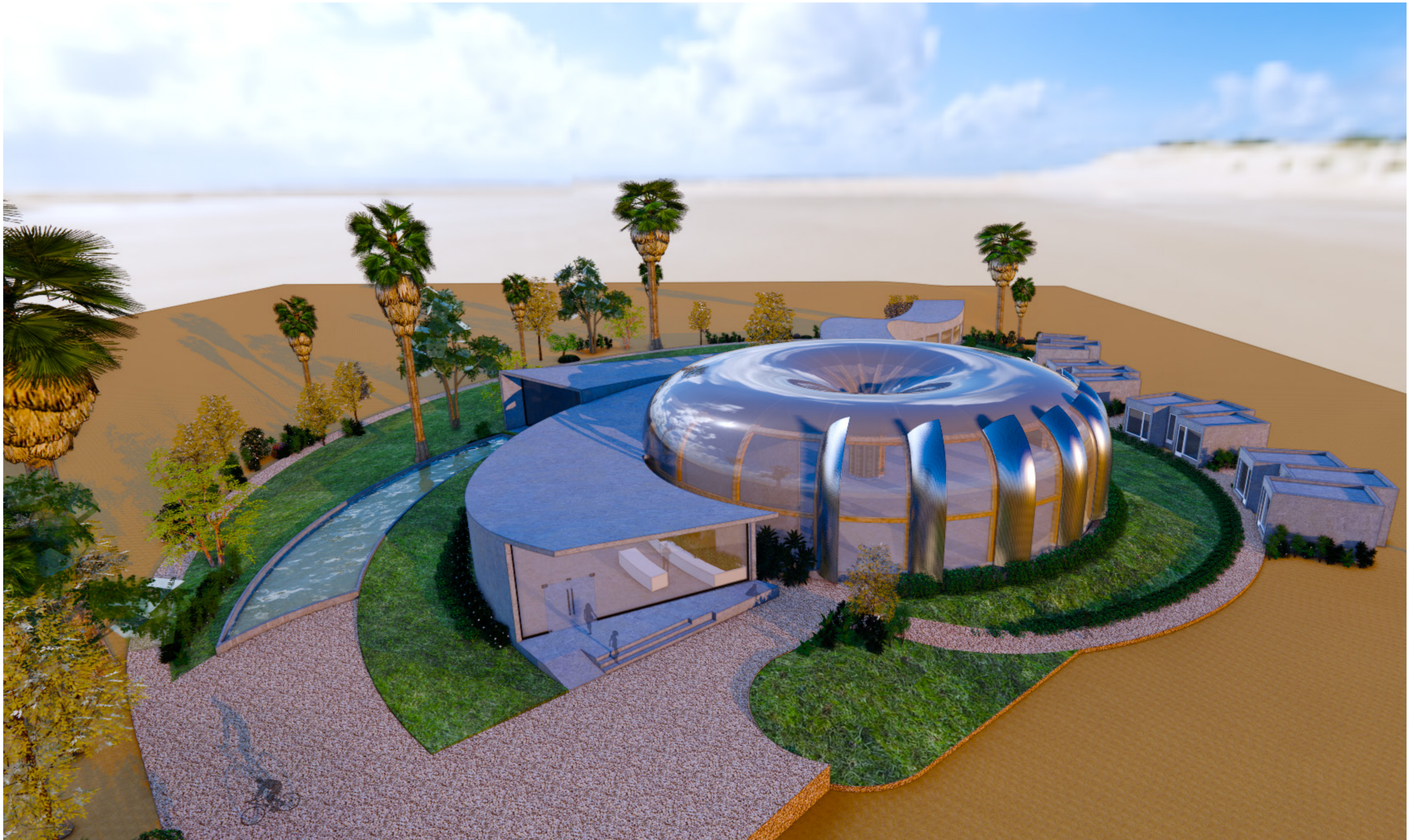









INTERNAL RENDERS



